

A new apartment

Ola Nylander

Professor in Architecture
Chalmers University of Technology
Göteborg



A new apartment

Ola Nylander

Professor in Architecture
Chalmers University of Technology
Göteborg



Brunnberg & Forshed Arkitektkontor, Stockholm

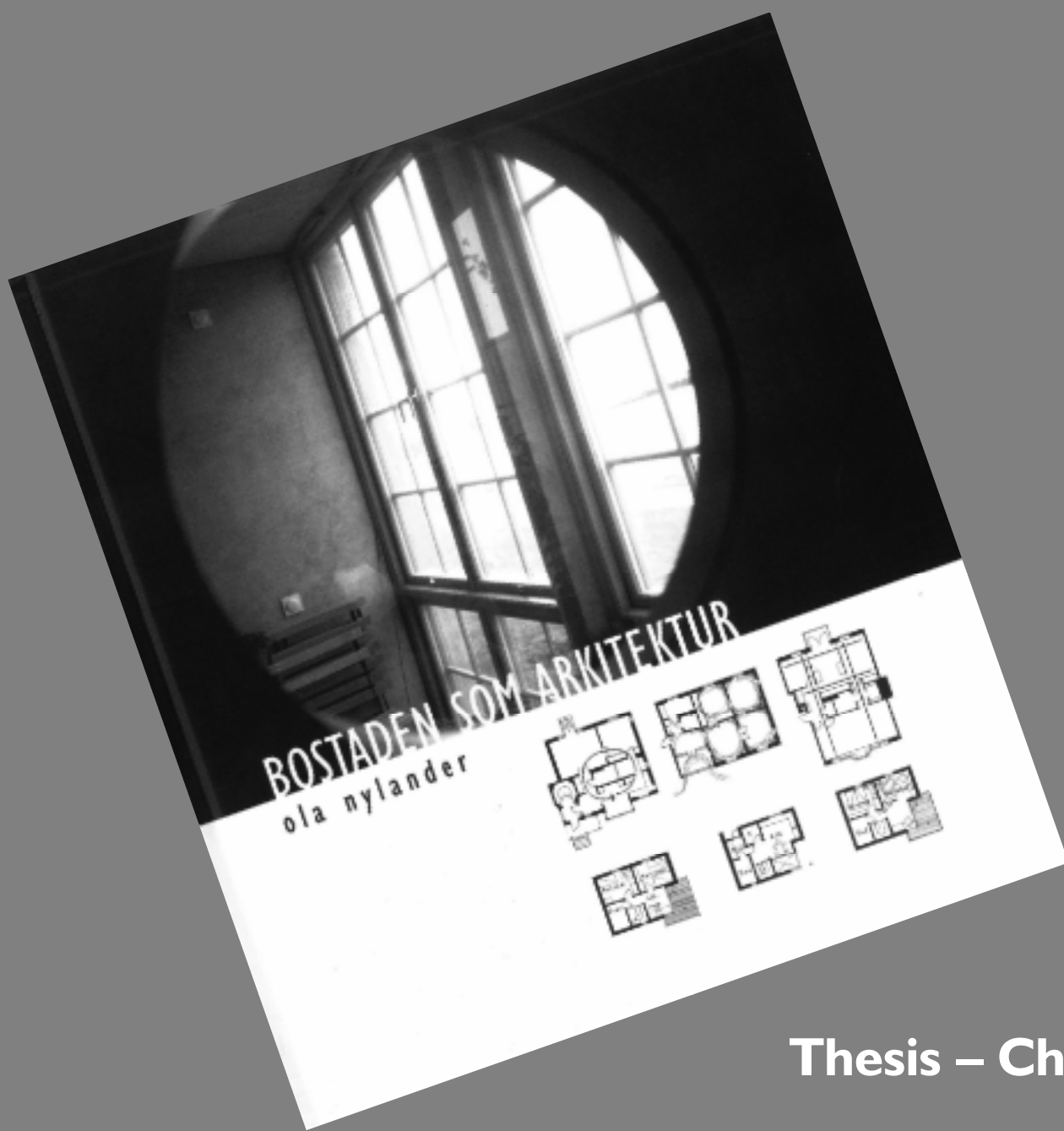

Thesis – Chalmers 1998



Architecture of the Home
2002, Wileys, London



...ell Forshed & Ola Nylander
**BOSTADENS
OMÄTBARA VÄRDEN**

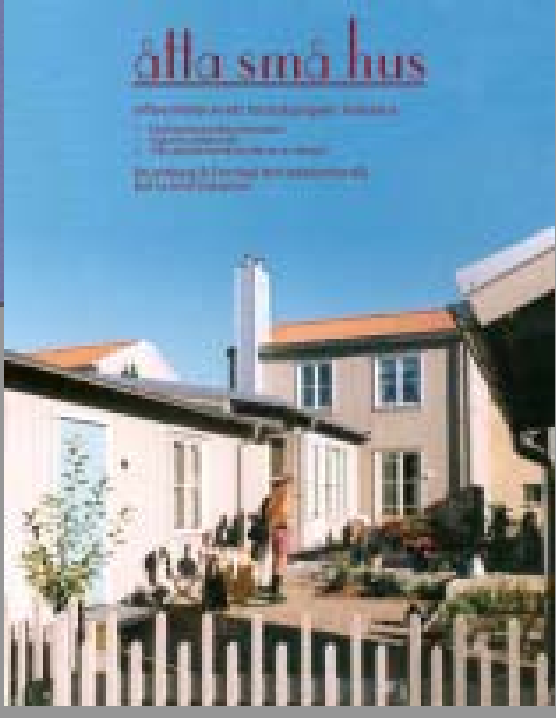
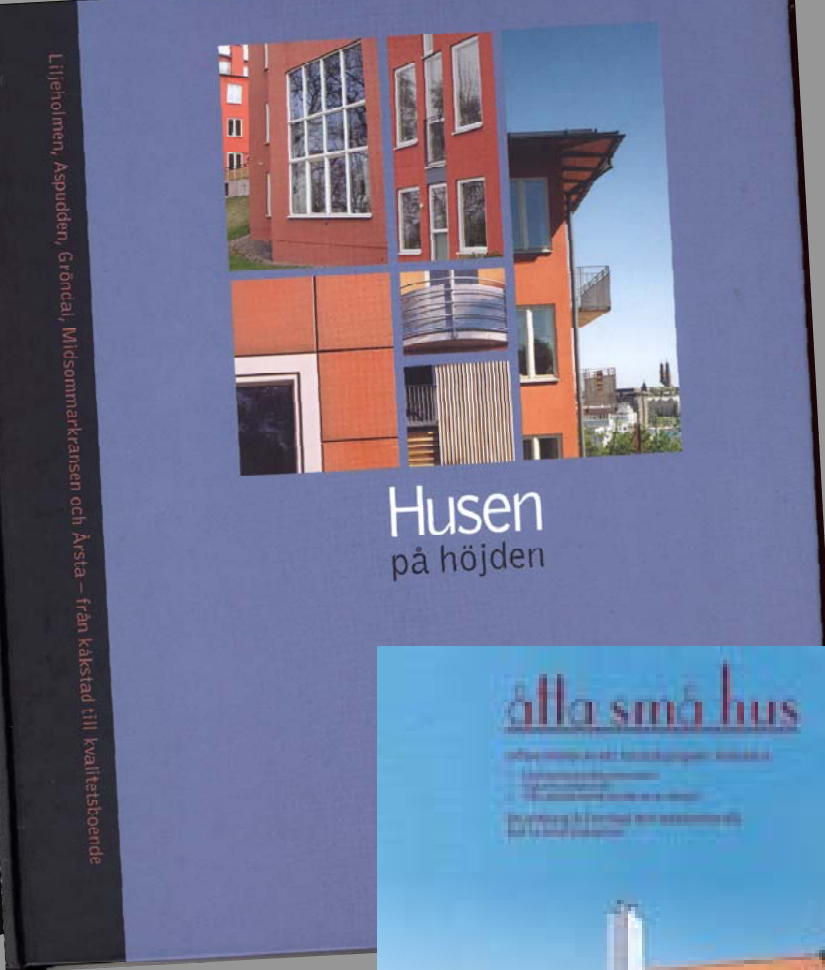

Pumpkällehagen

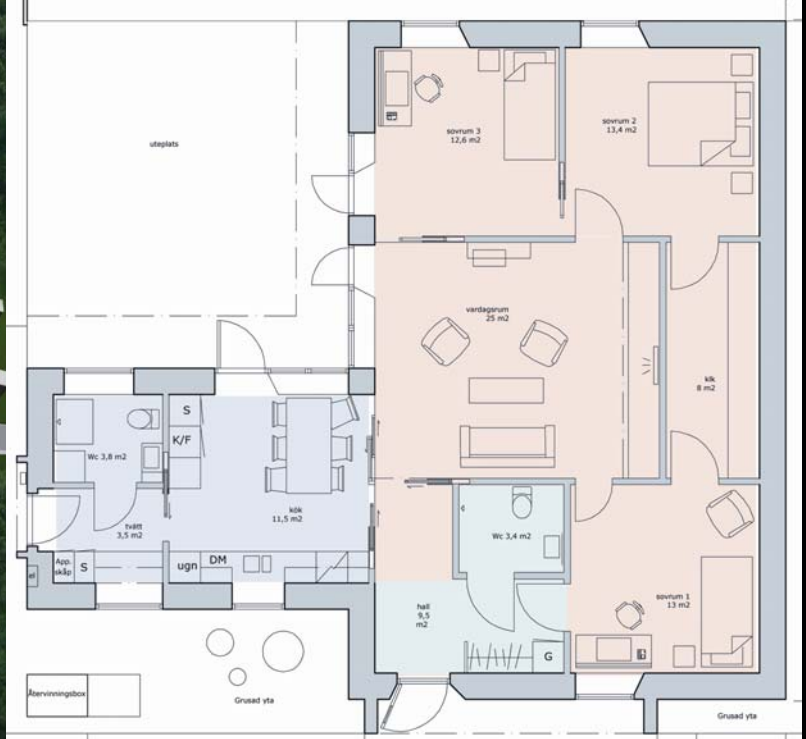

The new, inspiring apartment

The situation

The room

The organisation of space

The future

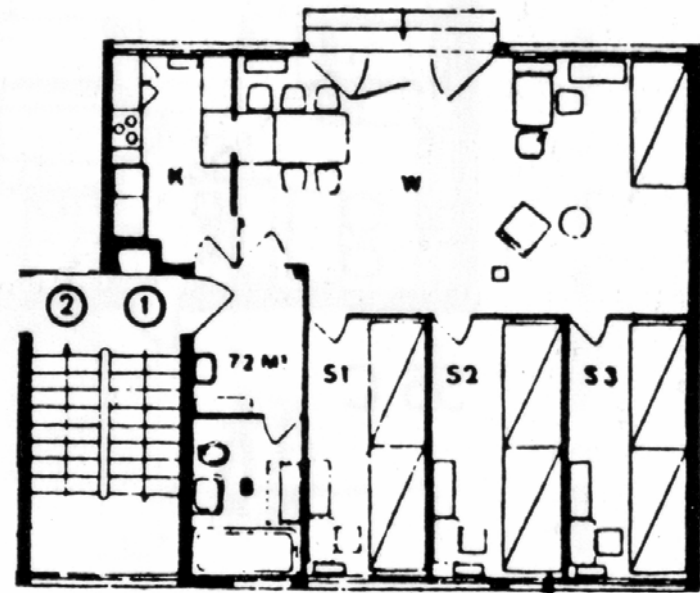

Mies van der Rohe 1927

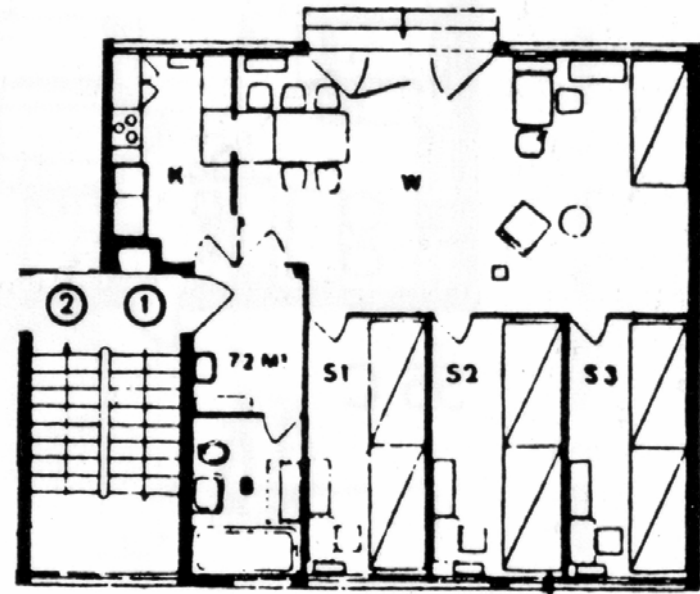
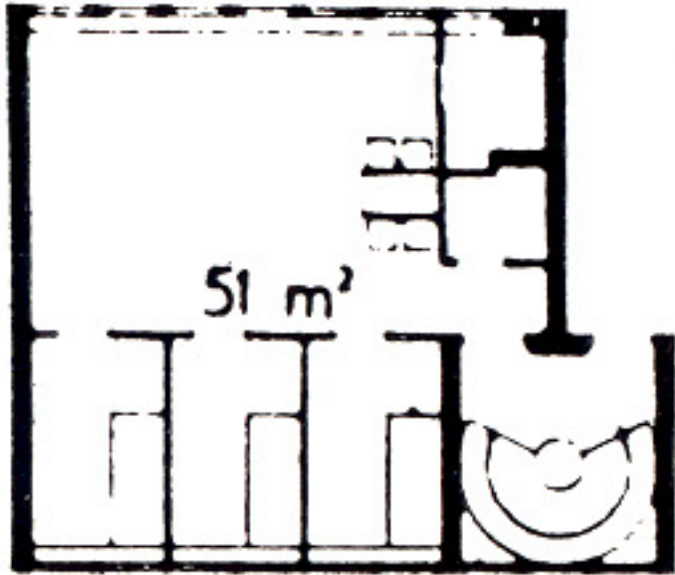

Mies van der Rohe 1927

1930 Stockholm
Zimdahl och Ahrbom

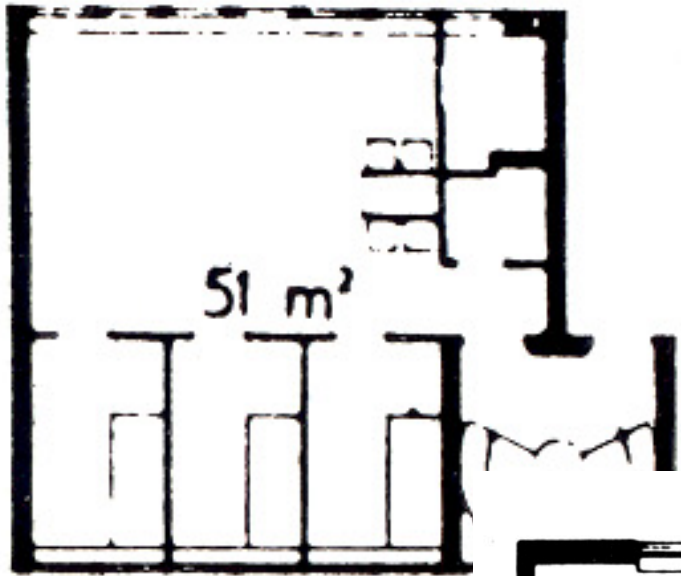

1950

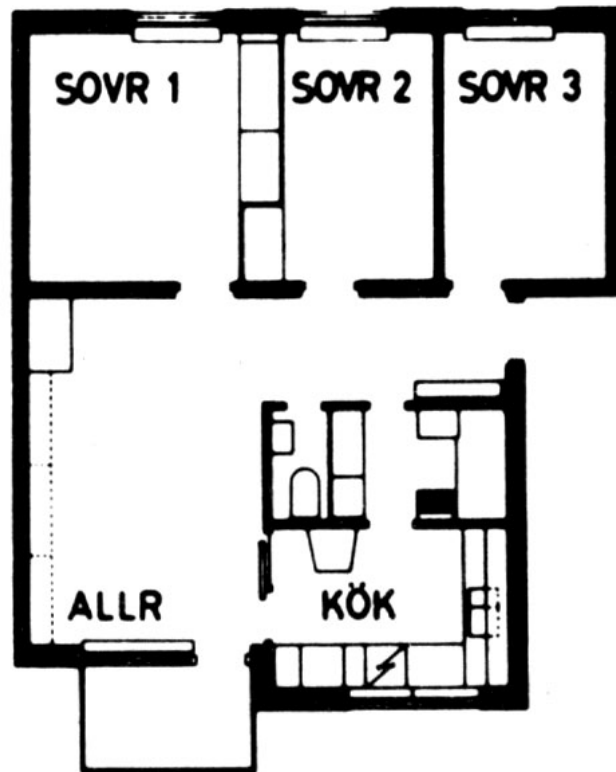

1930

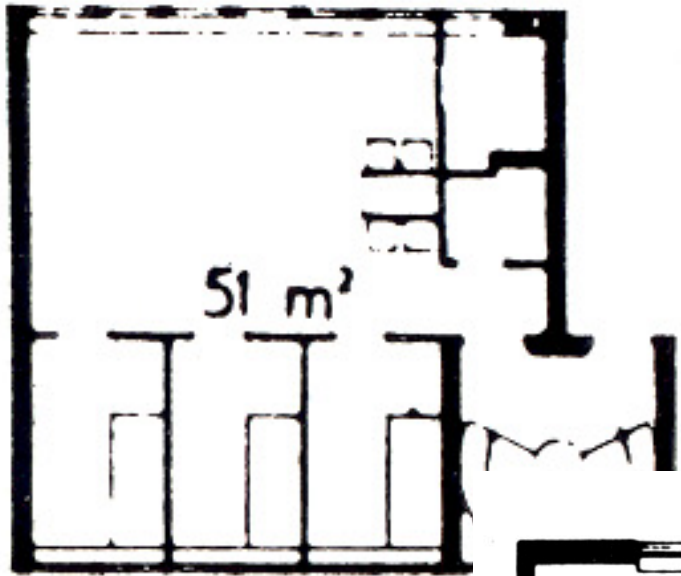

51 m²

1950



3 ROK 82 KVM

1930

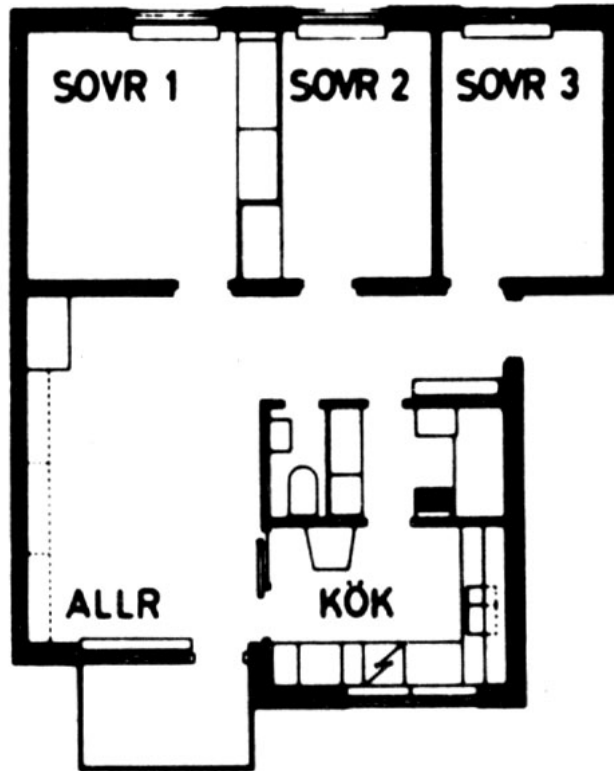

SOVR 1

SOVR 2

SOVR 3

ALLR

KÖK

Göteborg,
Wingårdh architects

2000

TODAY

- One function rooms
- Minimal storage
- No differentiation between public and private space
- No generality, no flexibility
- Work - home
- Function - experience

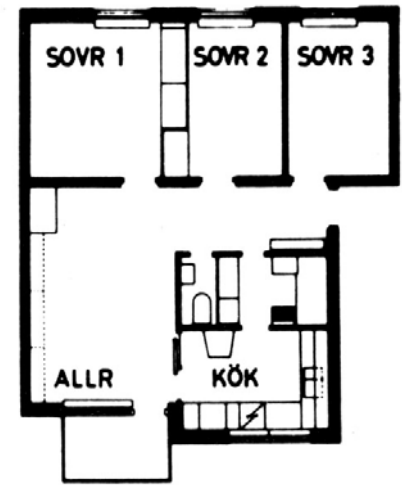
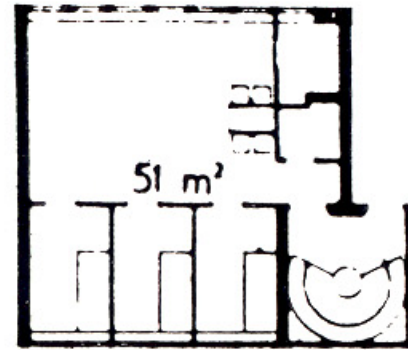



5

5,6 Alun perin koulua ja kylpylähotella varten mietitty korttel sai muotonsa yleisen arkkitehtuurikilpailun tuloksena (Arkkitehtuurikilpailuja 2/1997). Gullichsen-Vormalan suunnittelema Dockside satama-altaan reunalla muodostaa päätöksen Kallahden alueelle ja lyö alkuhaudit Aurinkolahden rantarintamalle. Arkkitehti edustaa merihenkistä asumista par excellence, mutta kuollut pohjakkeros surettia.

7,8 As. oy Meripojalle lankesi epäkiitollinen tehtävä rajata julkinen aukio yksityisin asunnoin. Maalauksellista kalastajakylän rantatorin tunnelmaa ei ole tavoiteltu, lomahotellin vaikutelmaa ei ole pystytty täysin välttämään. Tilällisesti ja arkkitehtonisesti tilanne on kuitenkin Kirsti Sivénin toimiston suunnittelemana hyvässä hallinnassa. Aukiolle tekisi hyvää asukkaiden ehdottama näyttävä taideteos.



6

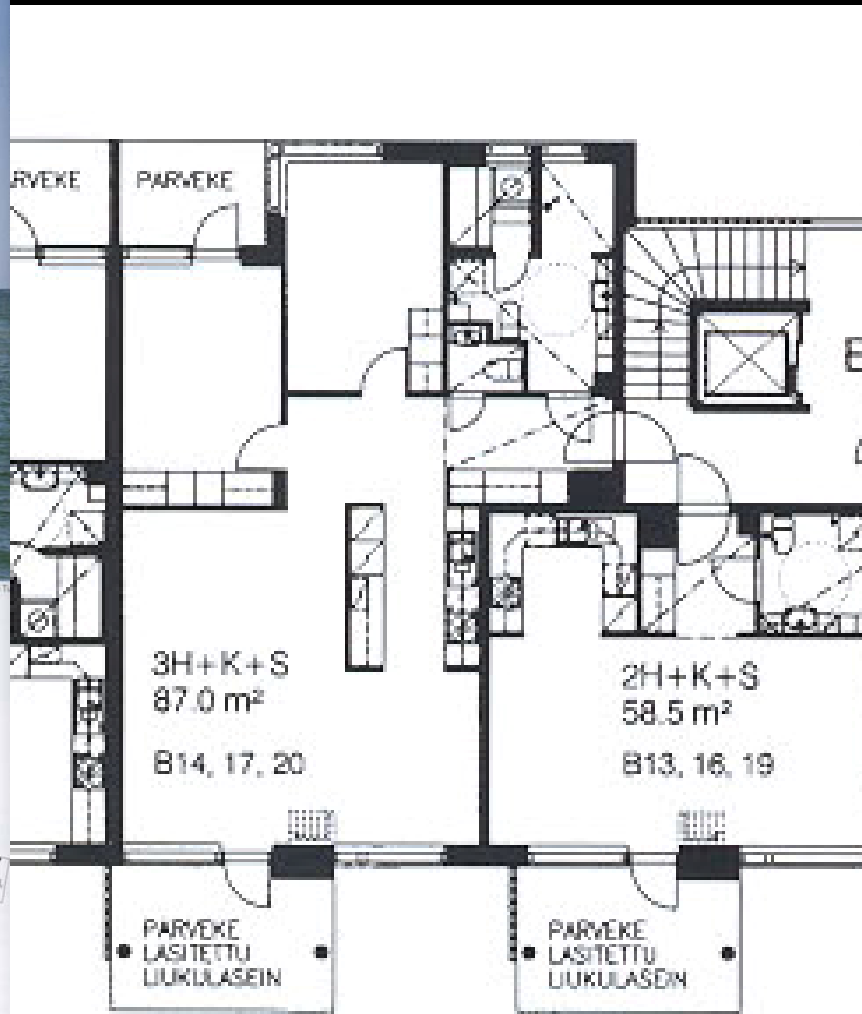



Jussi Tainen



Malmberg

6

1. krs / ground floor 1:500

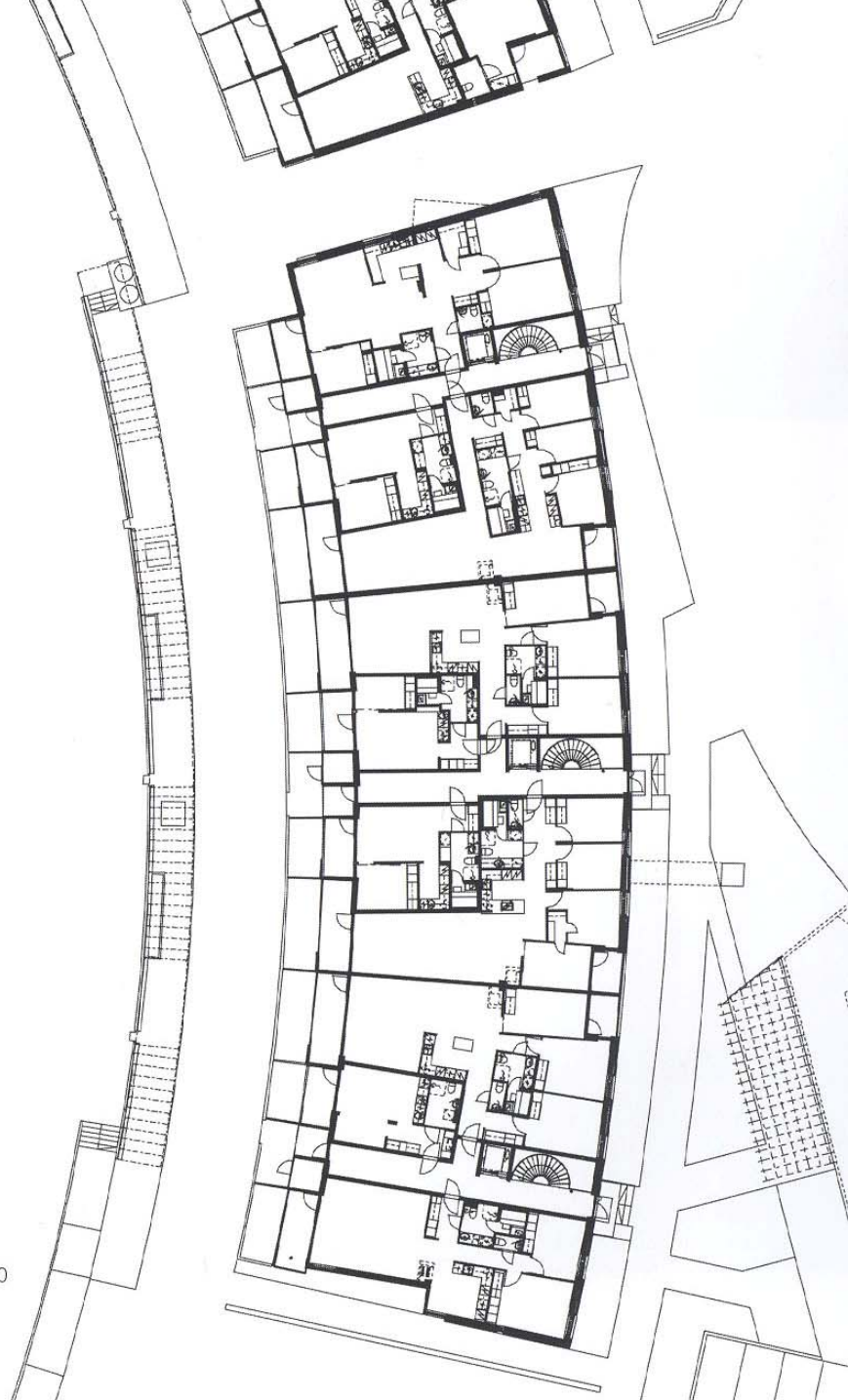

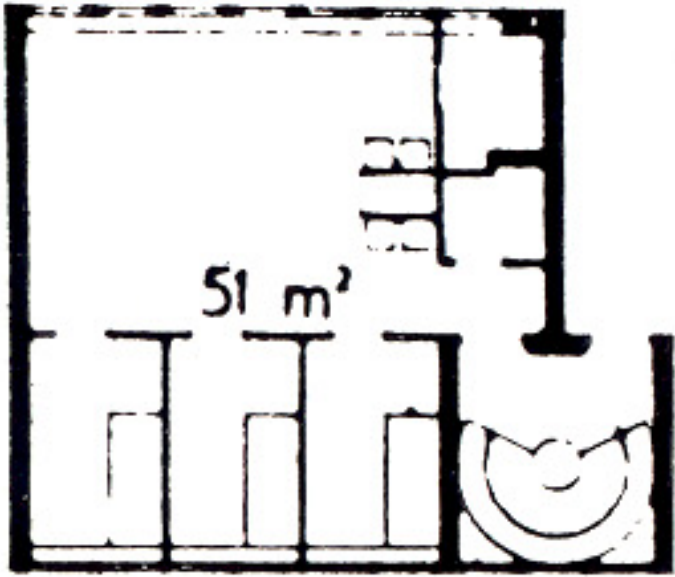

1930

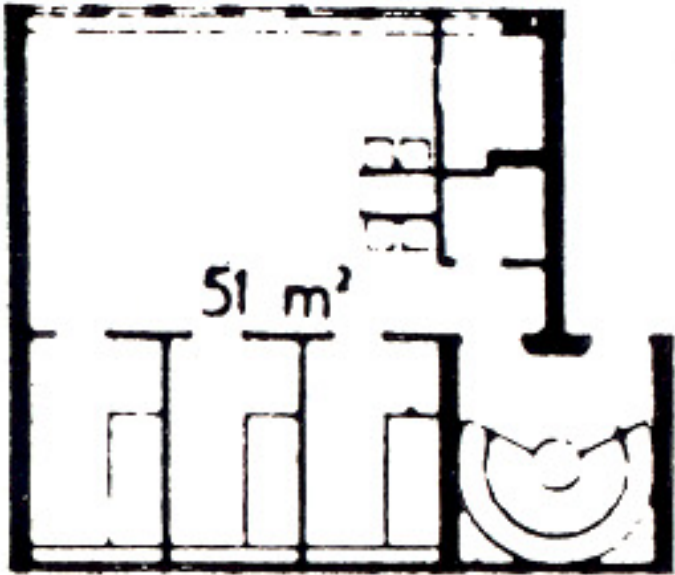

1930

Industrialization

Collective solutions

Minimi standard

Rest – eat - hygiene

2000

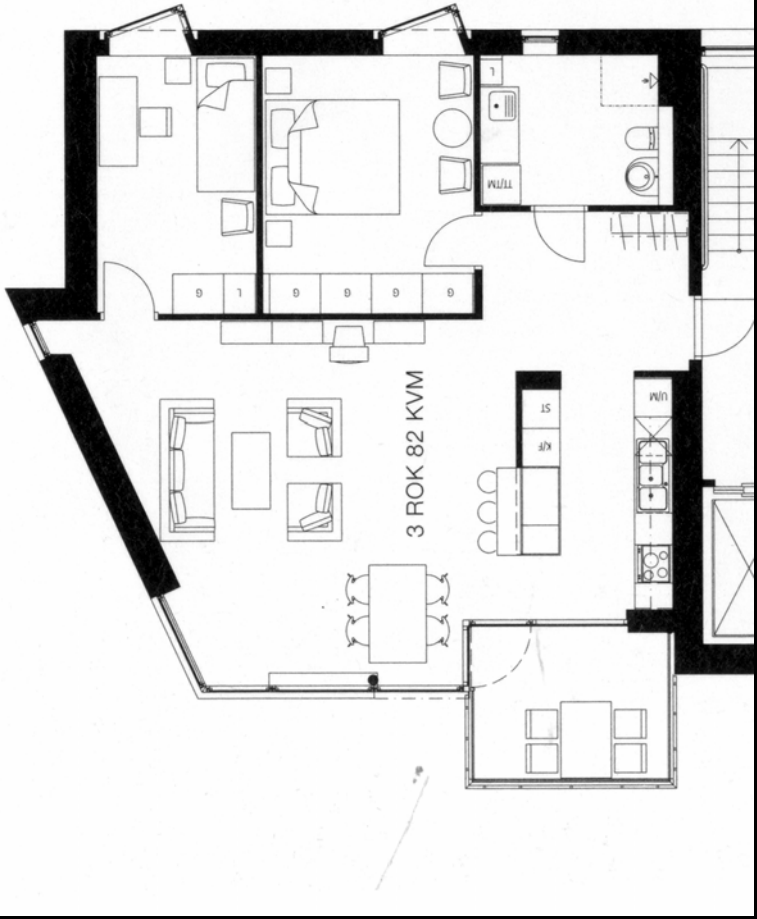

2000



New ideas of working Attractivity Design



H&M



Welfare in Scandinavia

LaCravate Dressman - Microsoft Internet Explorer

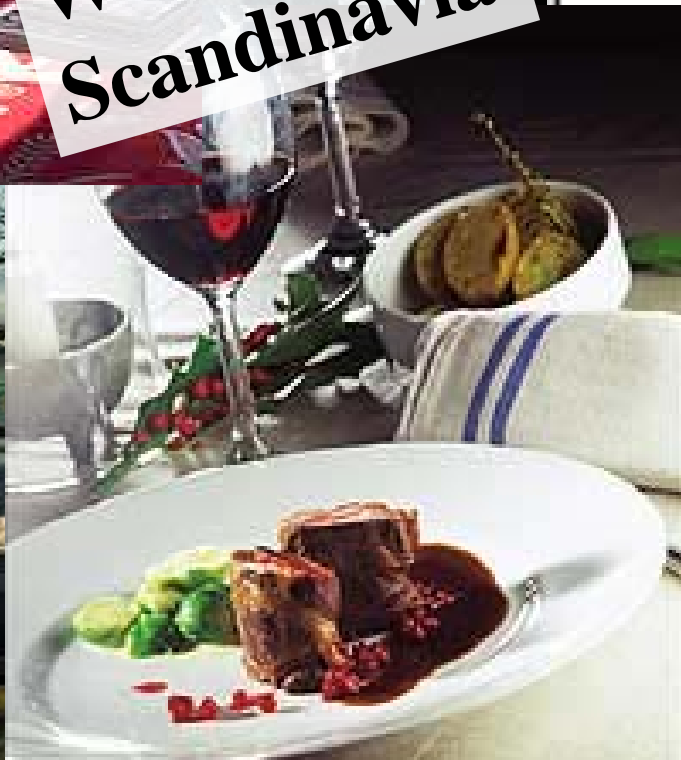

Necktie: 7025 Suit? yes no
choose to change: Suit Shirt

RICHARD FLORIDA
DEN KREATIVA
KLASSENS FRAMVÄXT

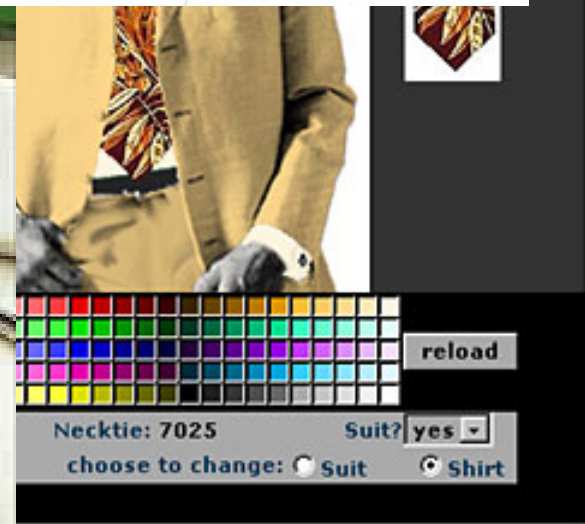
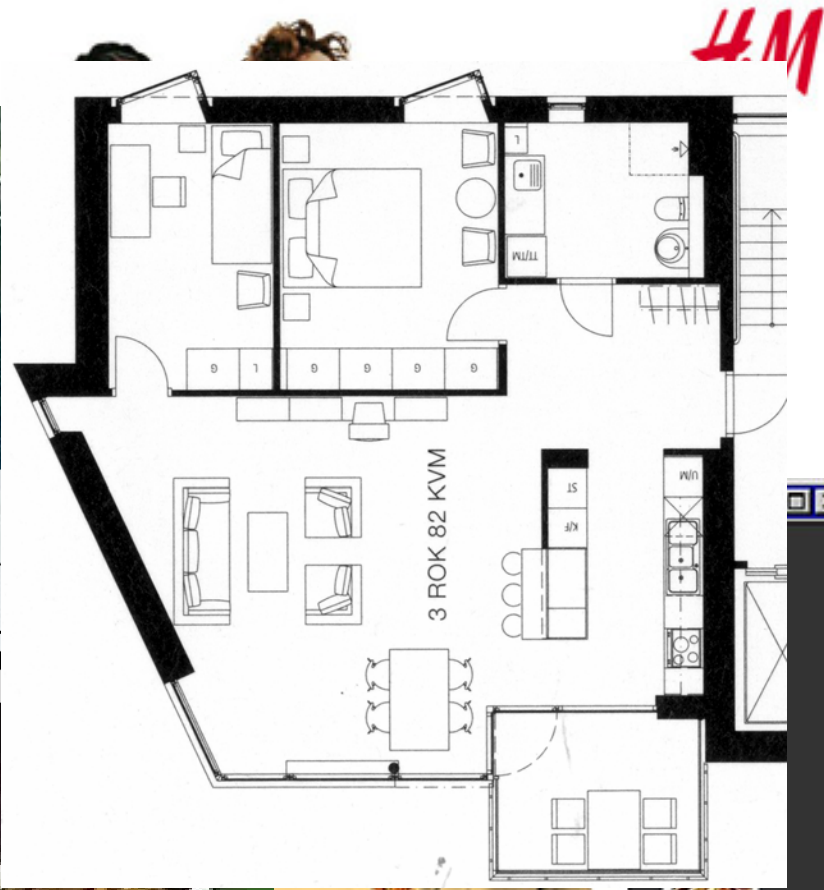

R Florida: The Rise of the Creative Class

The new, inspiring apartment

The situation

Customers market

Freedom of choices

Whealty middelclass

Freedom – order



The new, inspiring apartment

The situation

Customers market

Freedom of choices

Whealty middelclass

Freedom – order

Ideas from 1930

Someone make choises for you

Individuality?

Flexibility?

Attractivity?

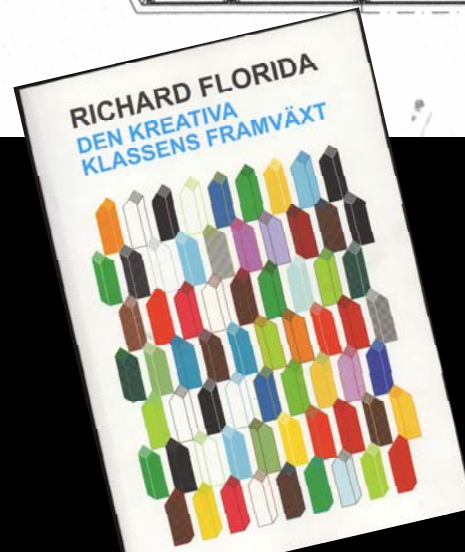

The new, inspiring apartment

The situation

The room

The organisation of space

The future

Development

The room

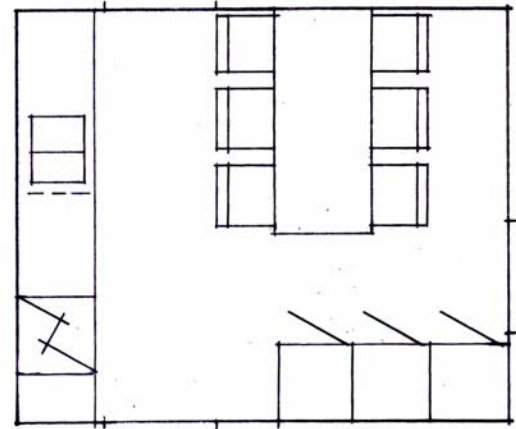
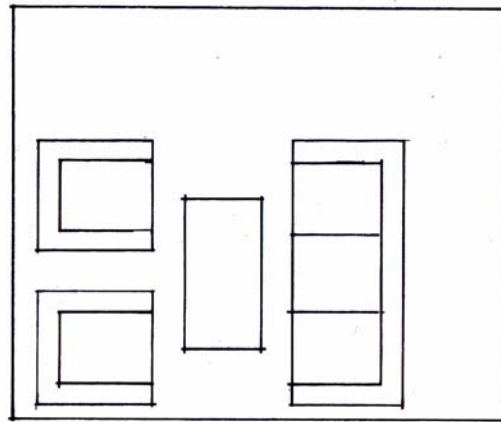
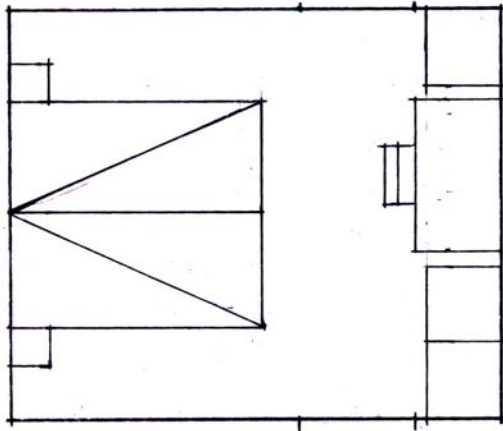
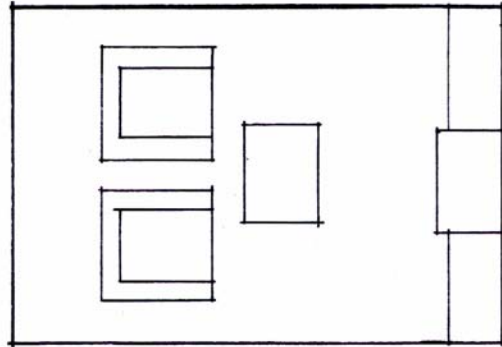

Development

**Room
Generality**

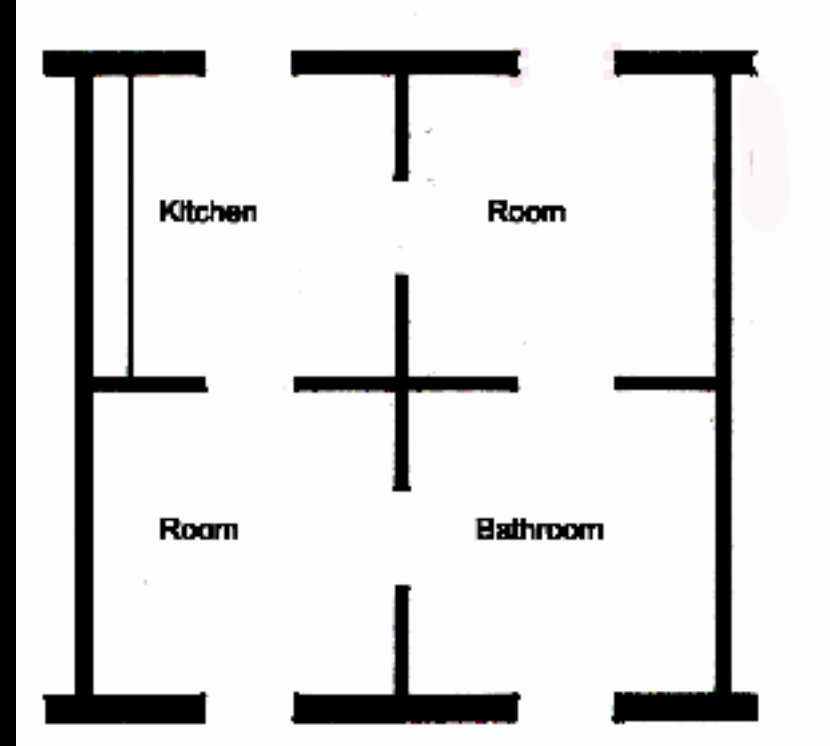

Exhibition: A home in Copenhagen

Development

Room

Generality

Individuality

*

9m

*

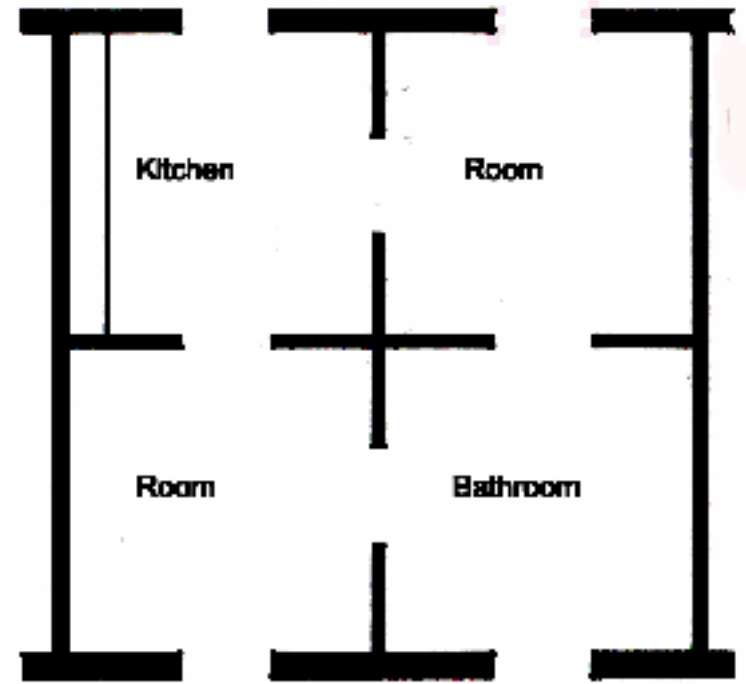

*

9m

*

Exhibition: A home in Copenhagen

Development

Room

Generality

Individuality

Democracy

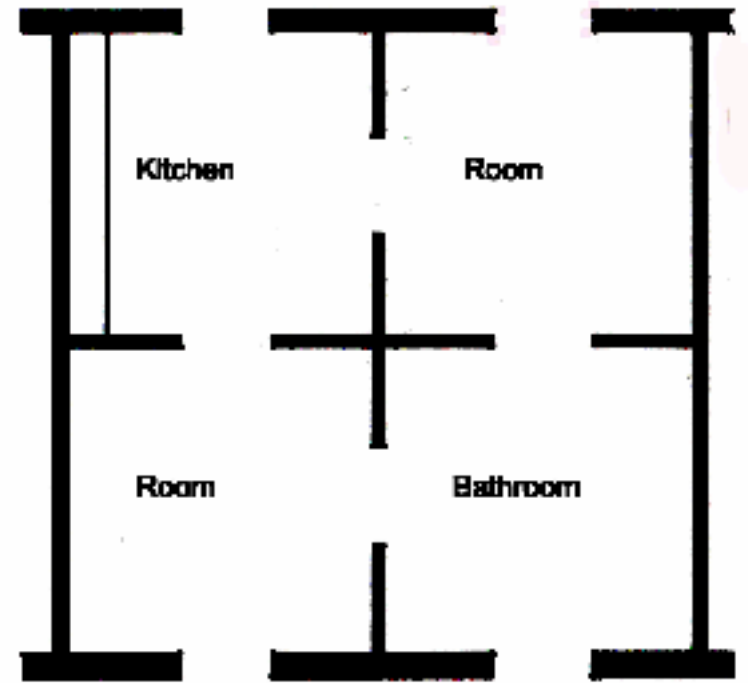

Exhibition: A home in Copenhagen

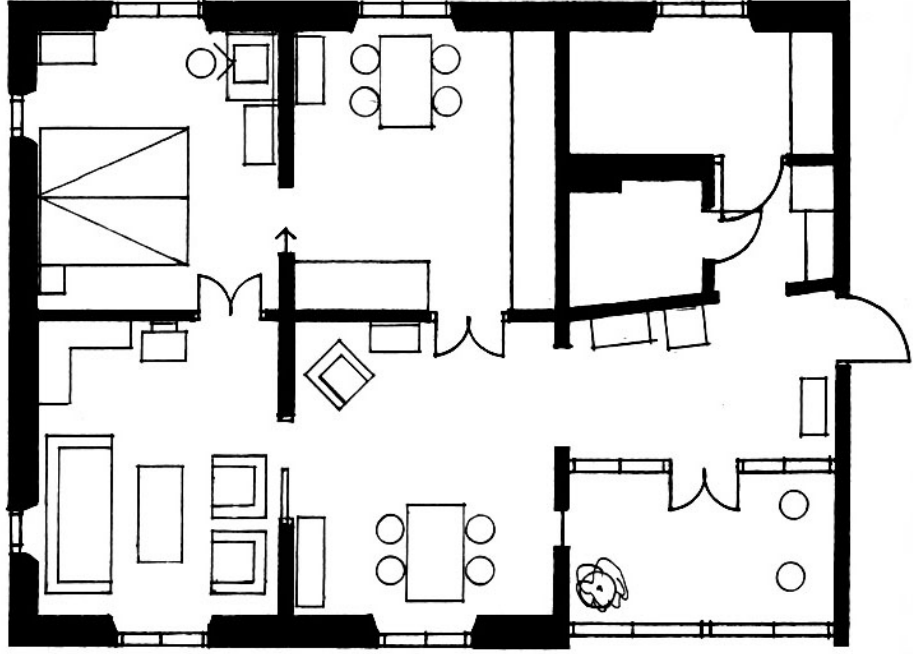

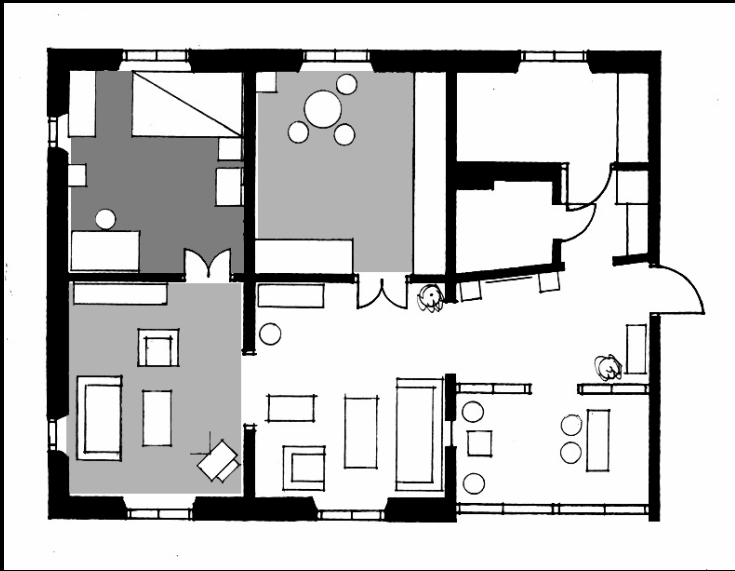
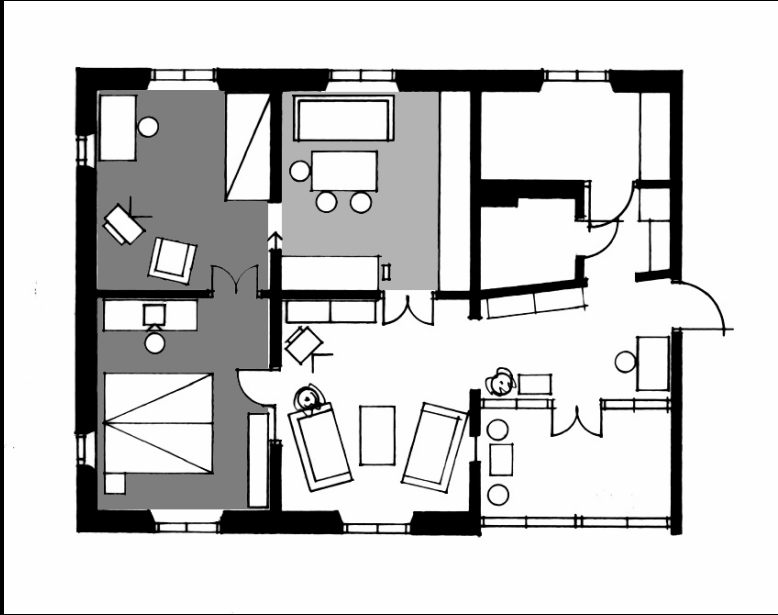
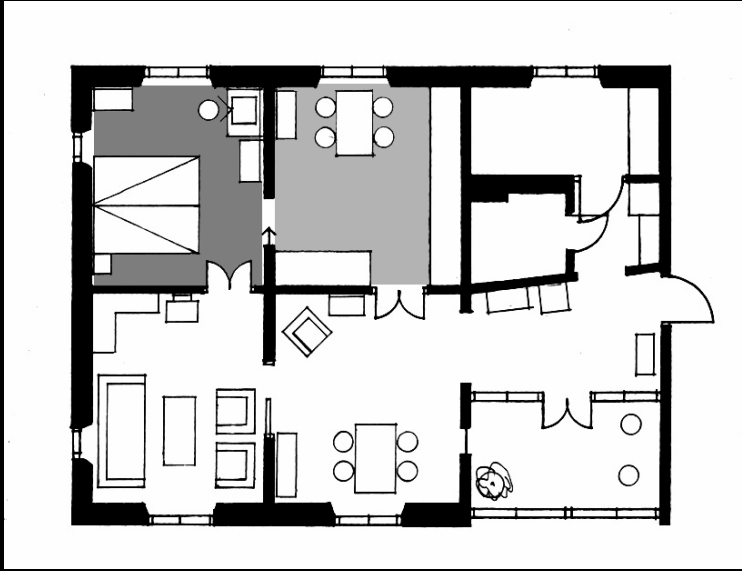

Respect - trust

**Material
Detailing
Openings**



Same material
Same detailing
Two openings



Development

Generality

Trust and respect

Express individuality

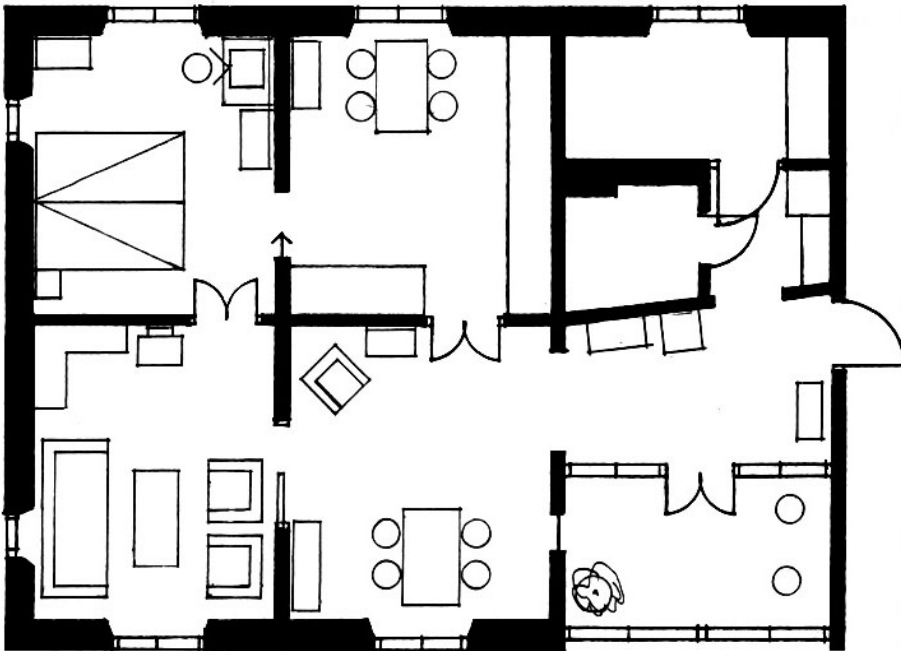



Annika Carlsson, Equator architects, Stockholm

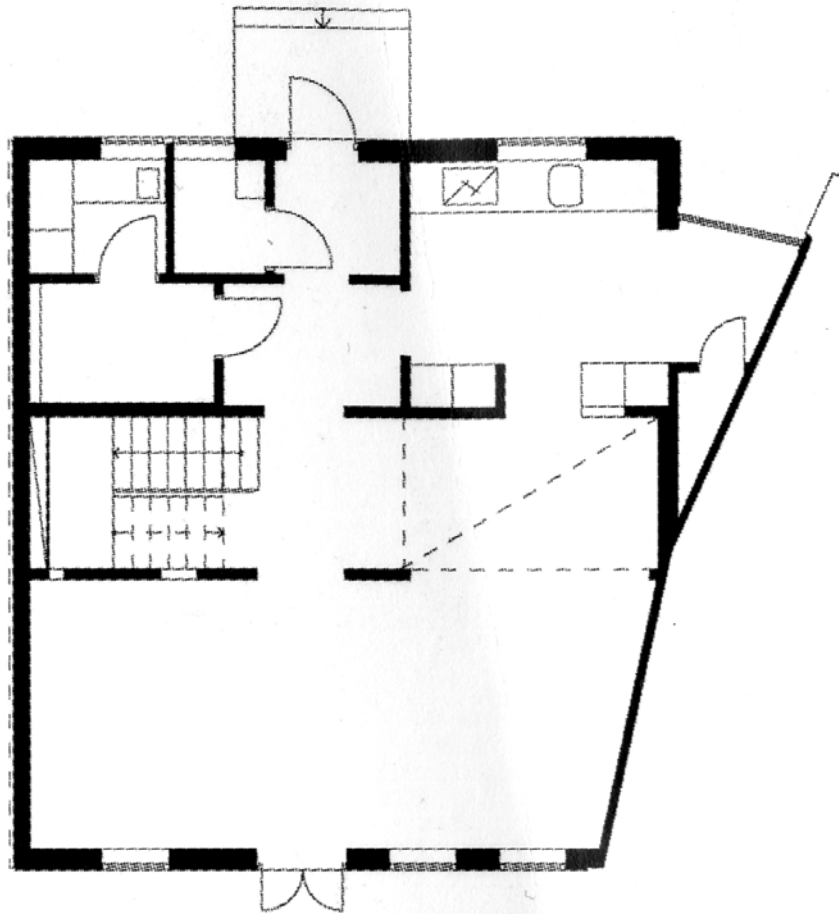

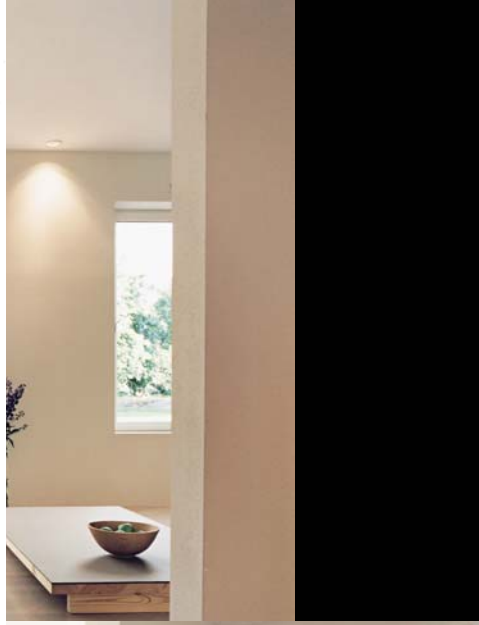
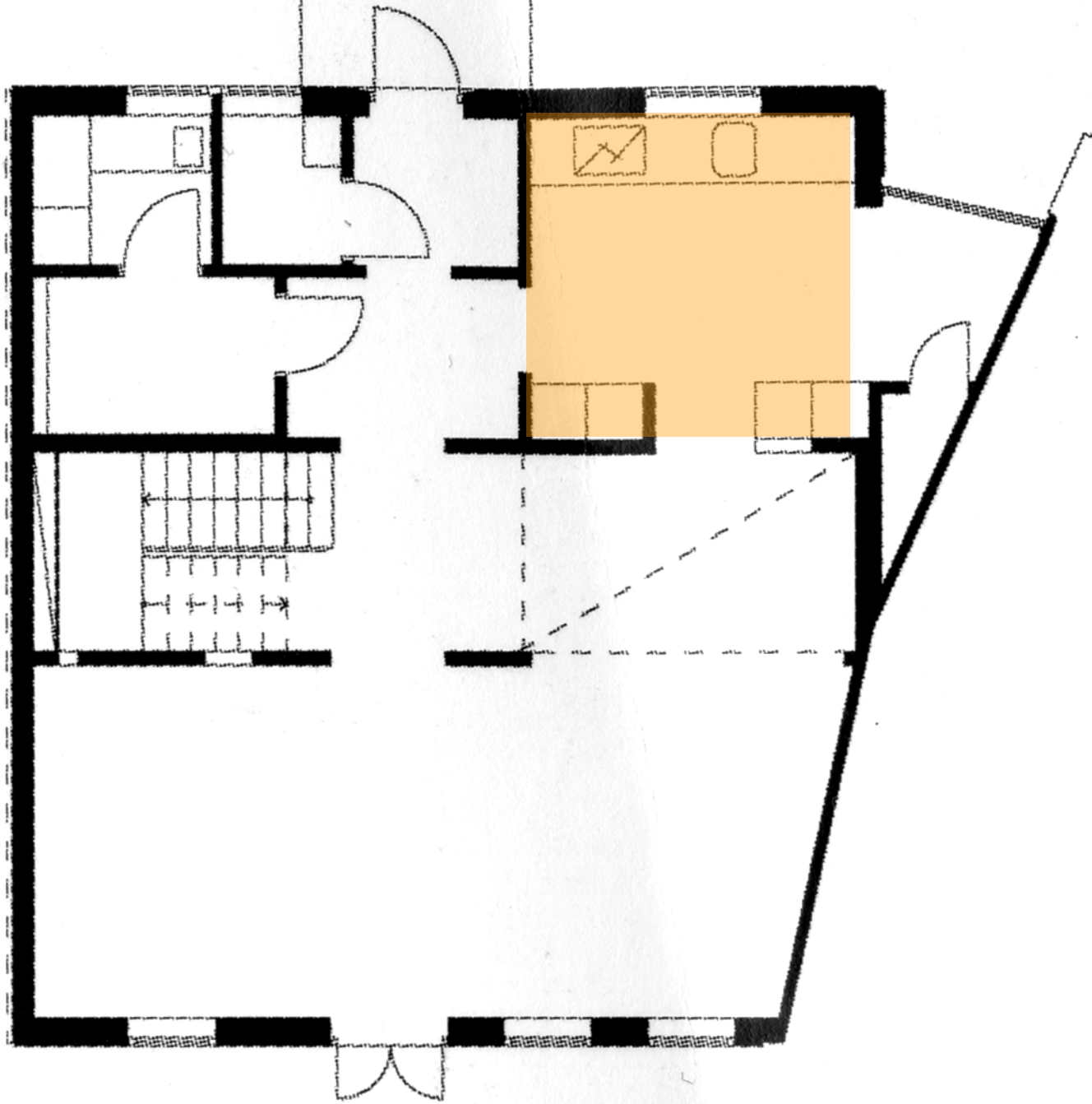

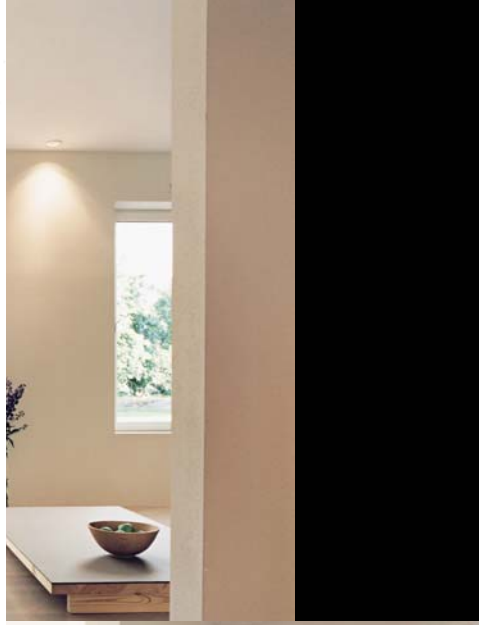
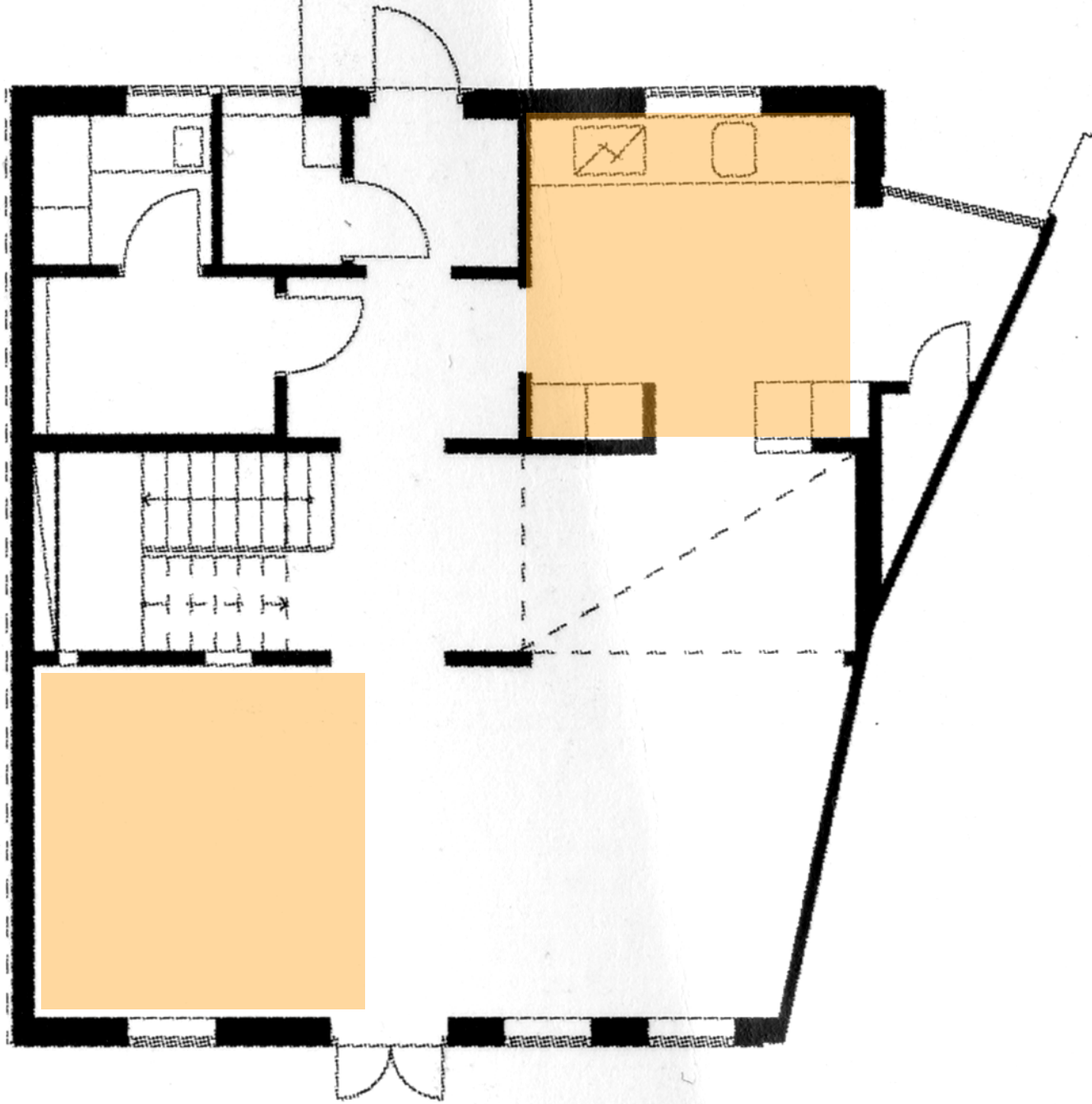

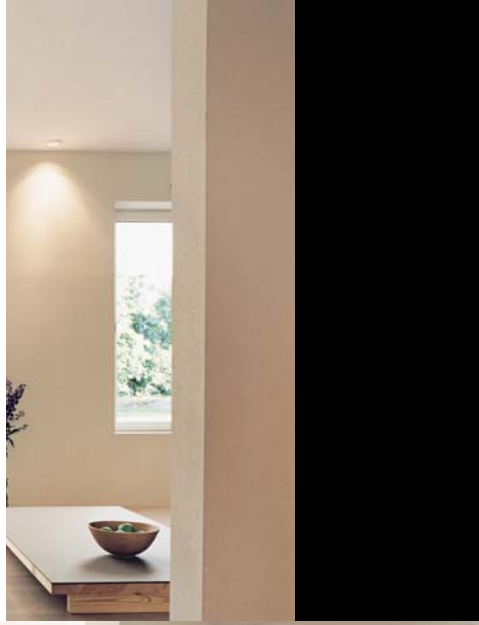

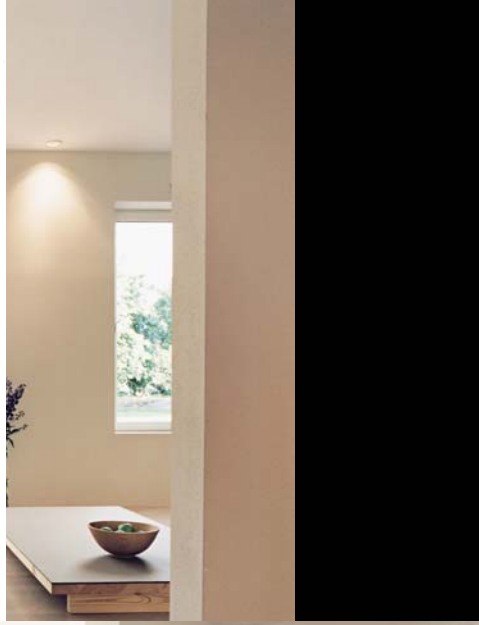

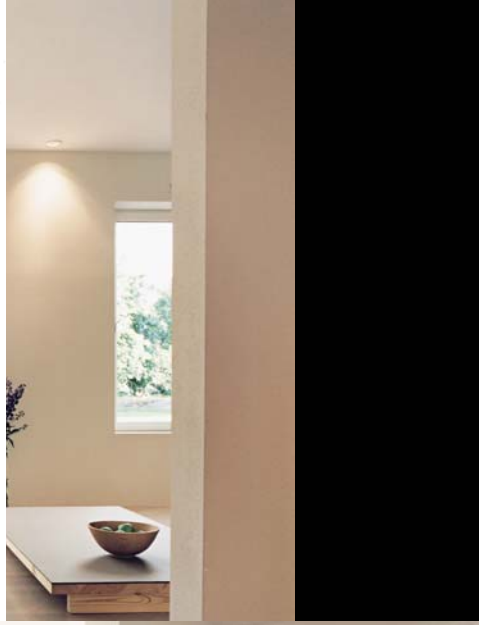



BLANMA

Generale room

3,6 x 3,6 minimum

Same material

Same detailing

Two openings



The Old, traditional room

One function rooms

One Opening

No generality, no flexibility

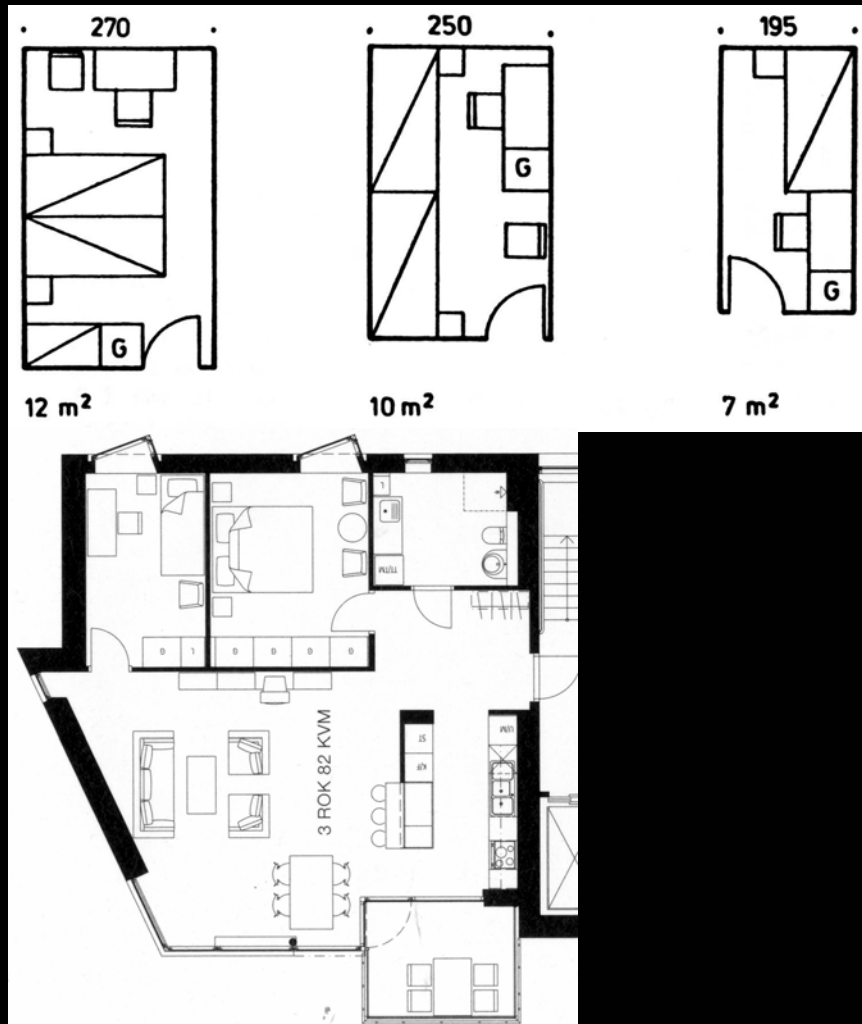

The Old, traditional room

One function rooms

No generality, no flexibility

”Big brother – decide”

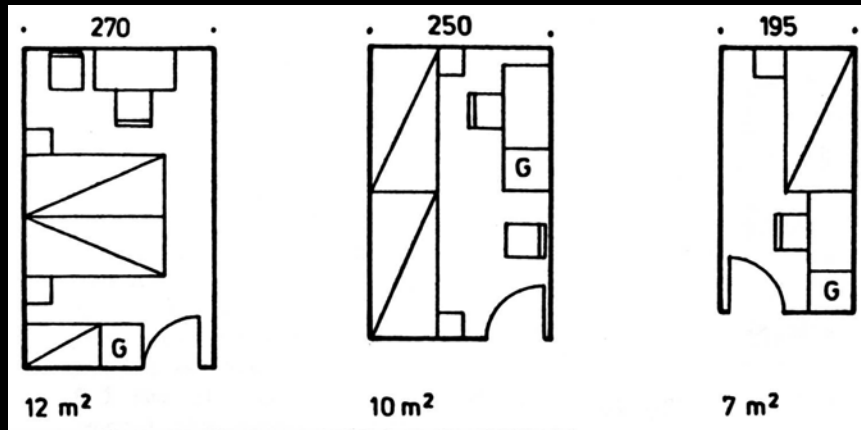

The New , modern room

Generality

Tenants Decide

Democracy - individuality

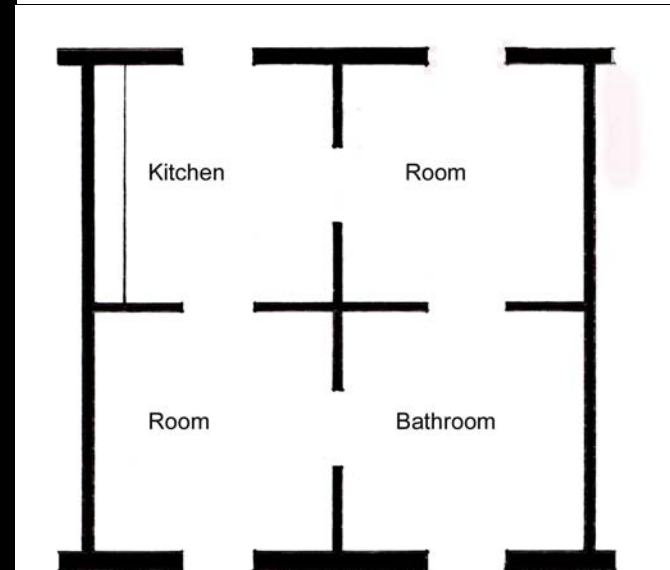
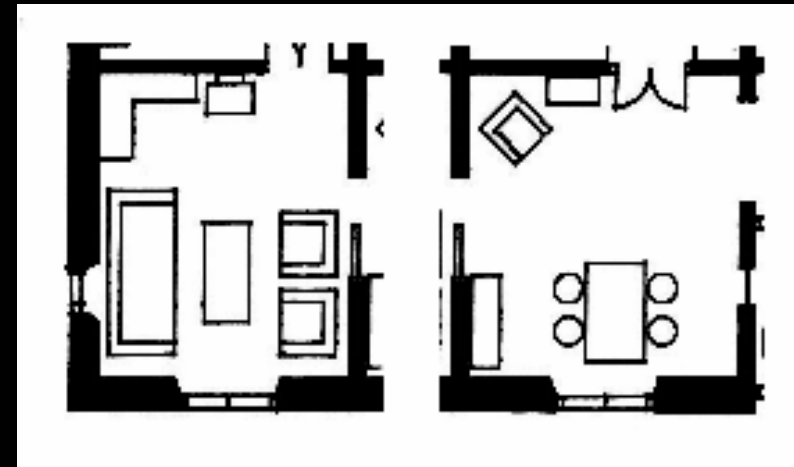

The new, inspiring apartment

The situation

The room

The organisation of space

The future

Development

Room

Generality

Complexity

Democracy

Space organisation

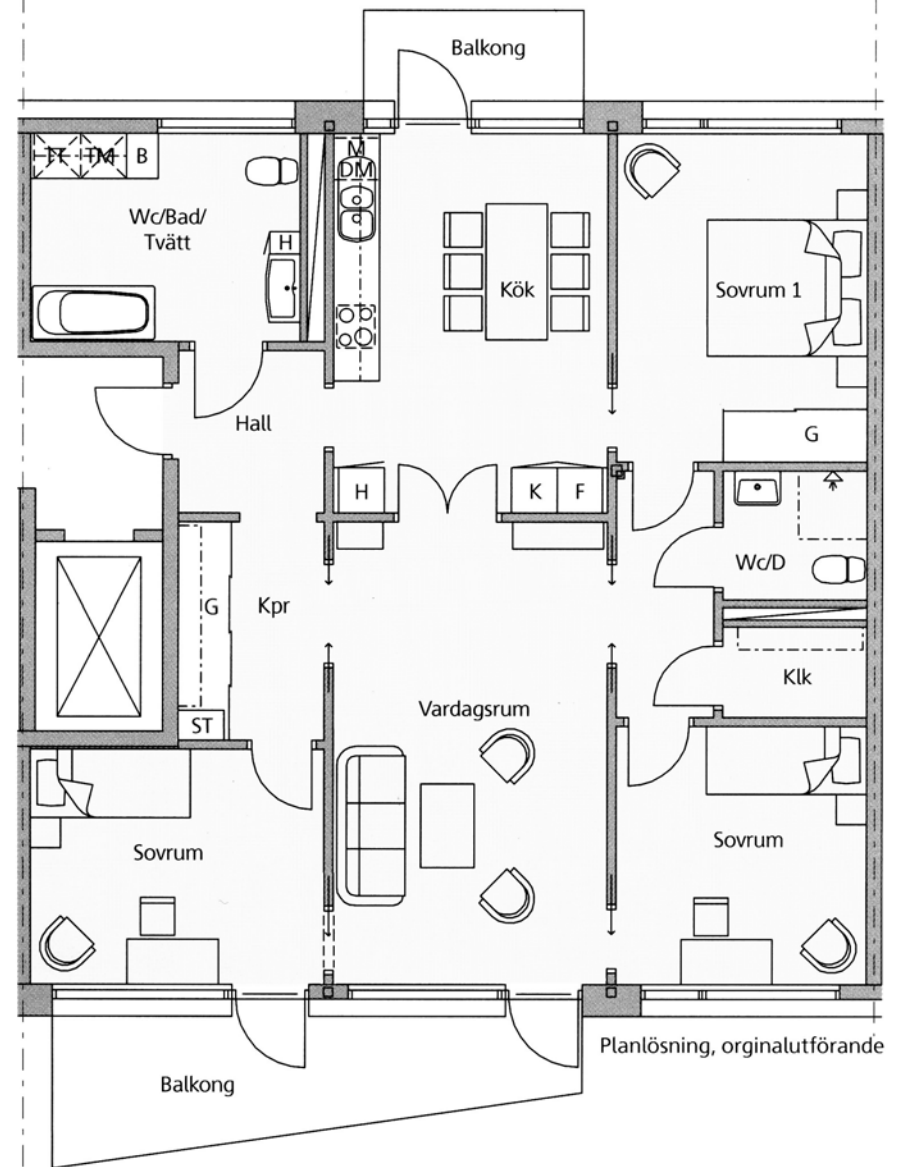

Development

Room

Generality

Complexity

Democracy

Space organisation

Flexibility

Public and private

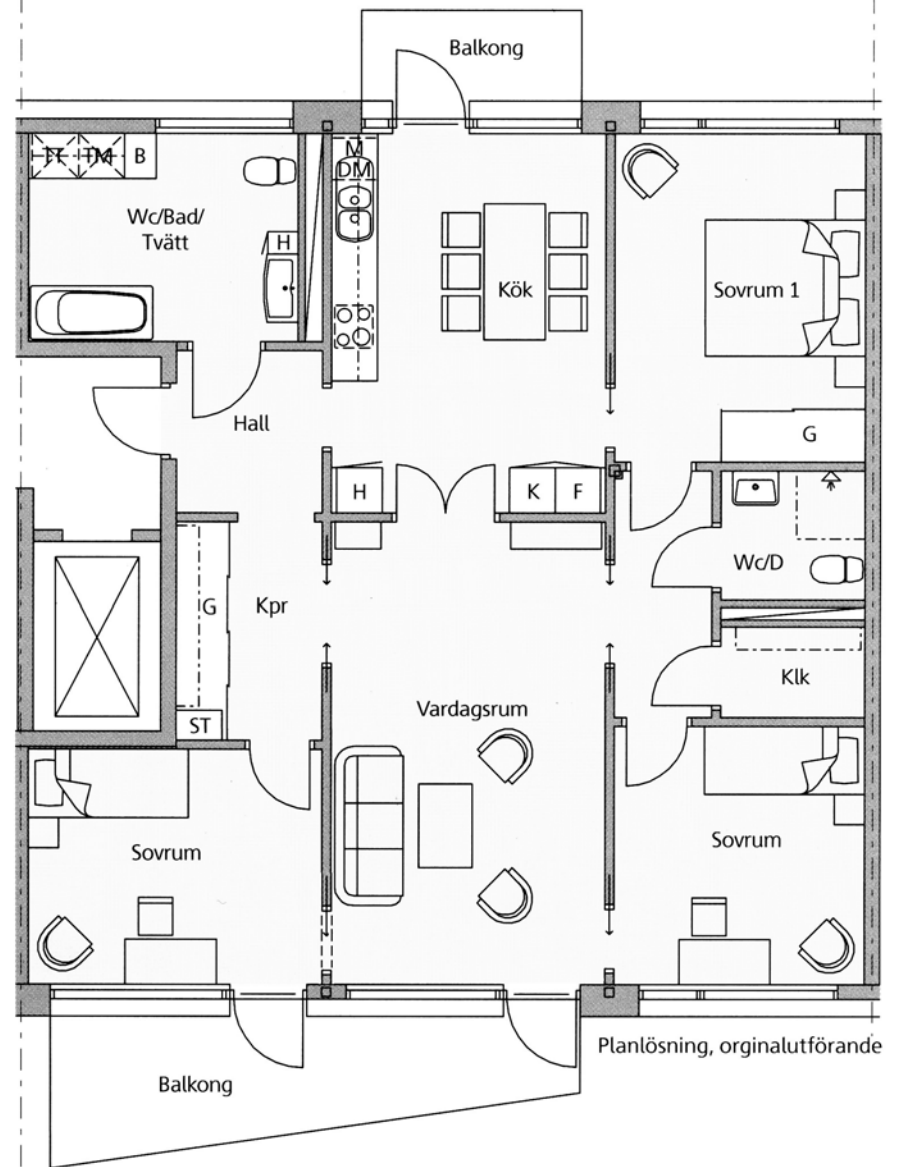

Development

Room

Generality

Complexity

Democracy

Space organisation

Flexibility

Public and private

Complexity (Richness)

Movements

Axiality

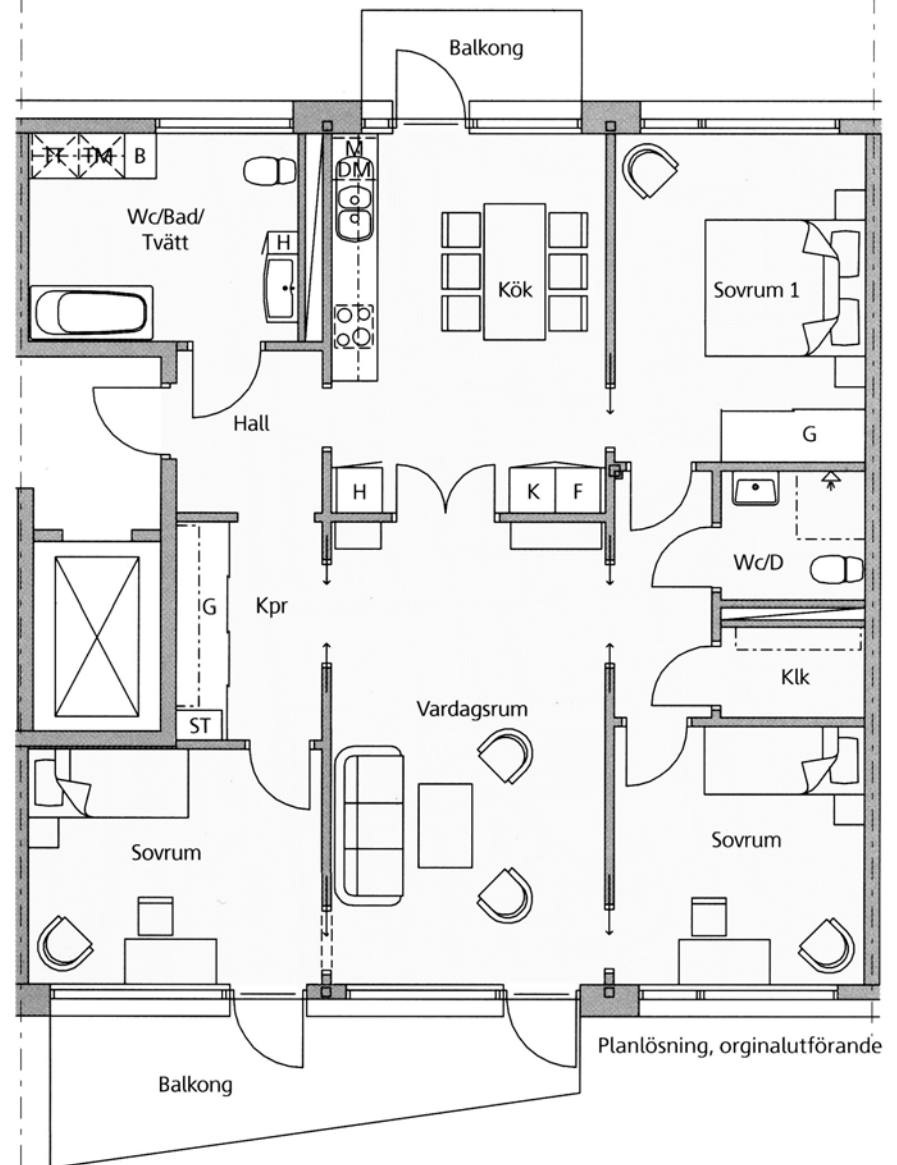

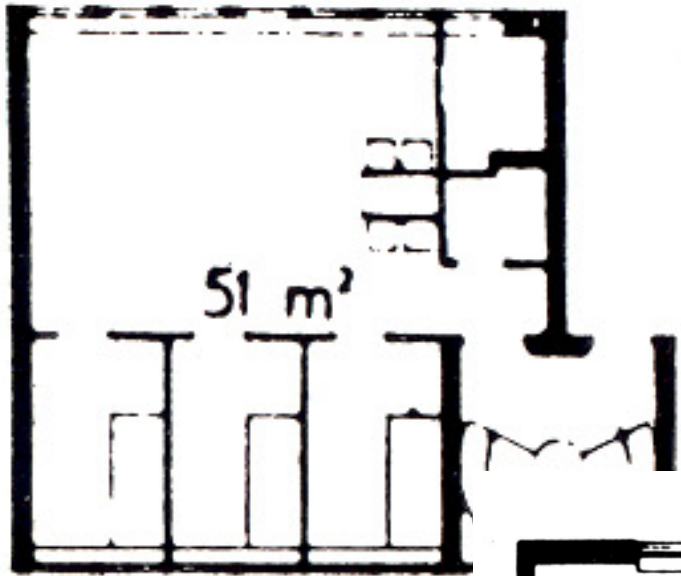

1950



1930

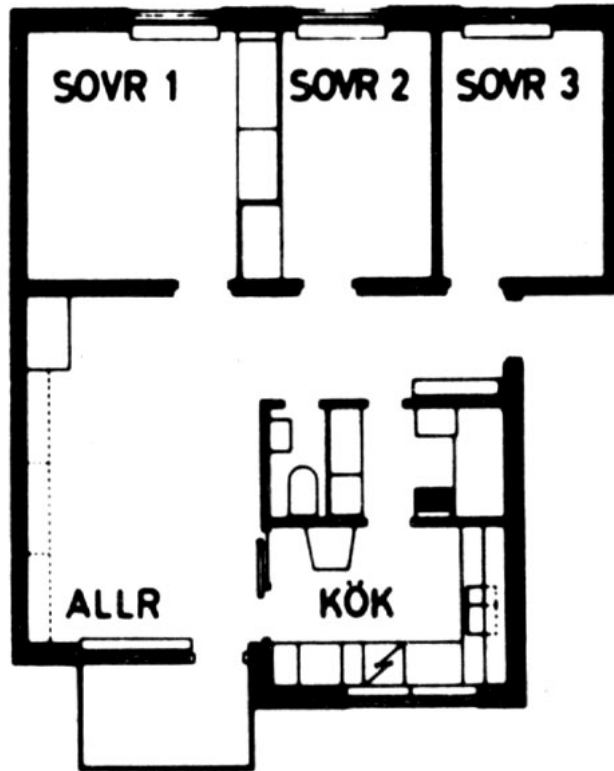

2000

Space organisation

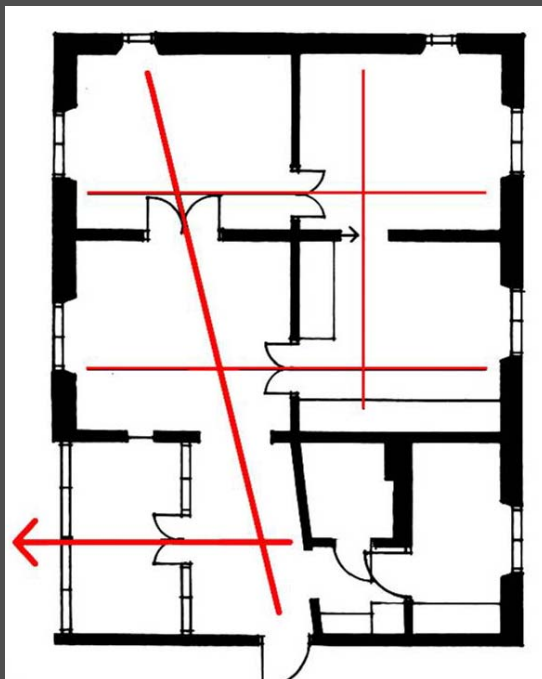



3 room & kitchen, 82kvm, 1993.

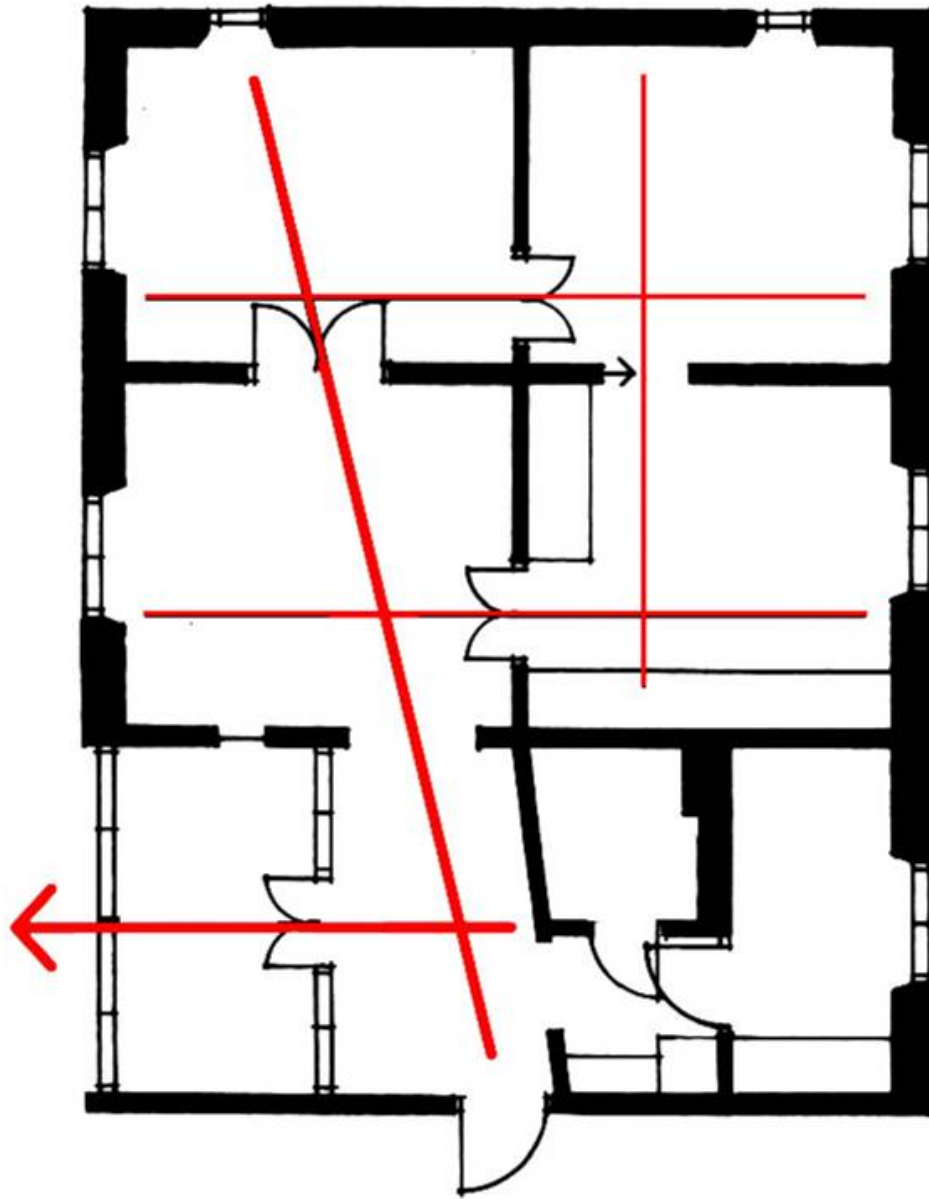









Axiality

The length of the axes
The number of spaces
Similarities and symmetries
The form of the openings
Starting points
and goals

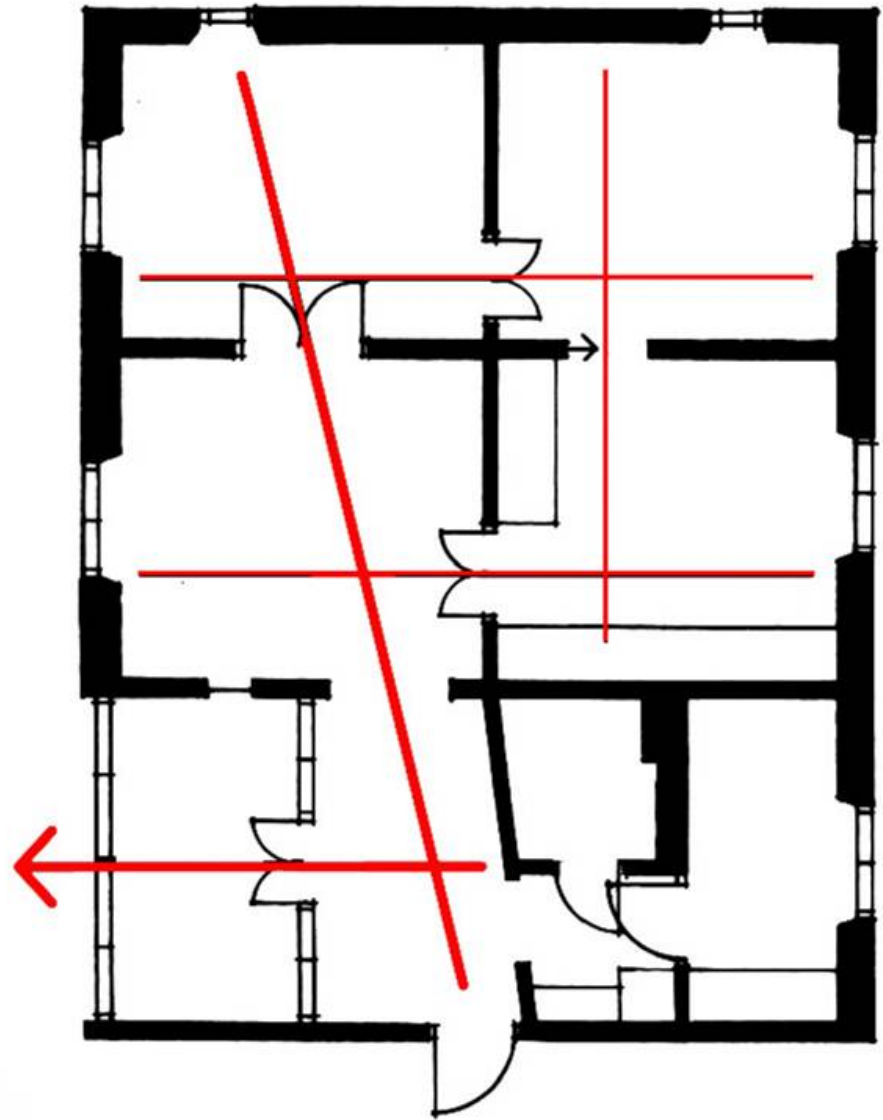



Wingårdhs architects, exhibition flat Bo01, Malmö 2001.

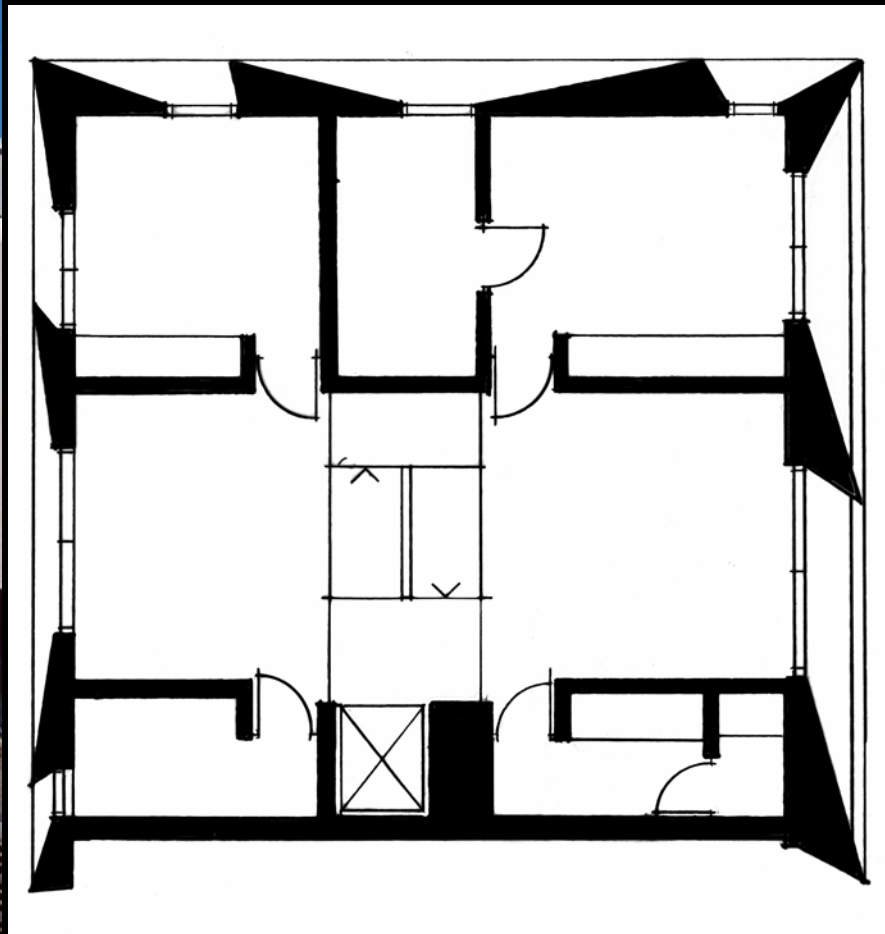

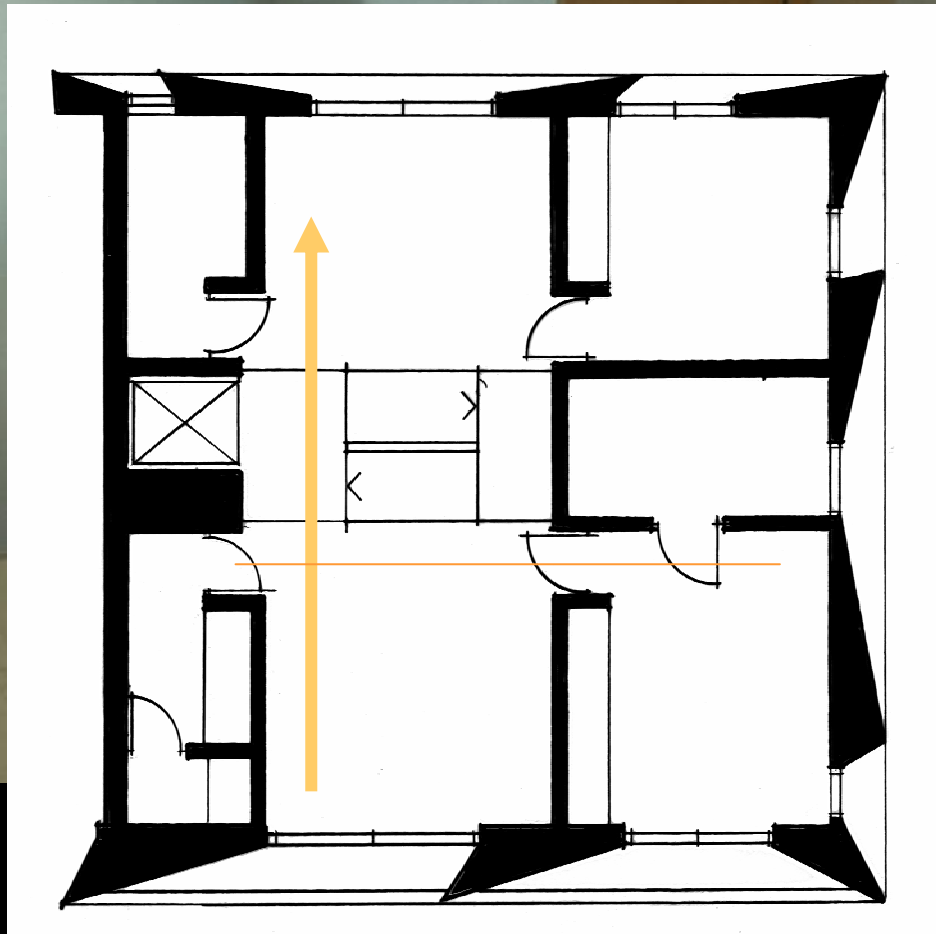

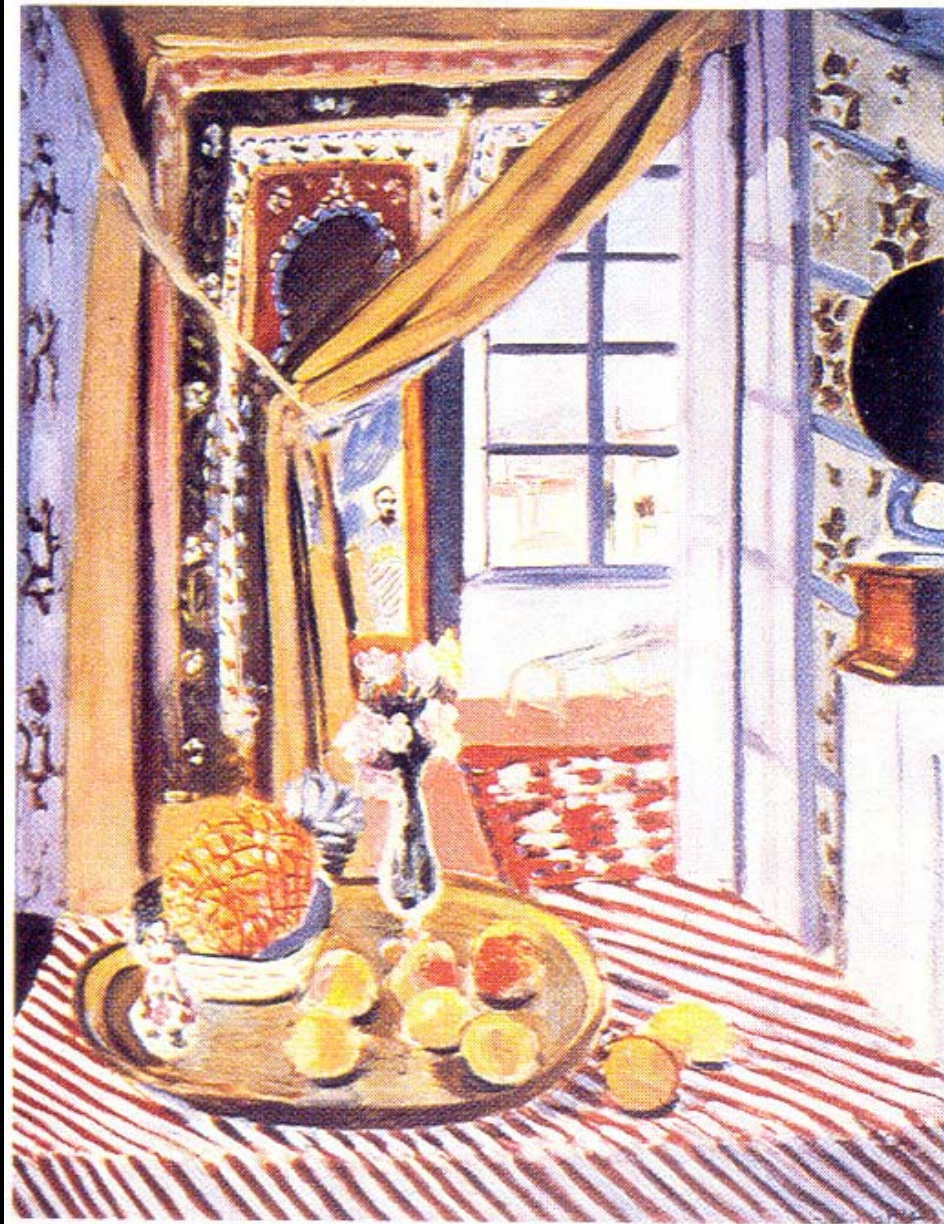

*H Matisse: Interiör
med grammofon 1910*

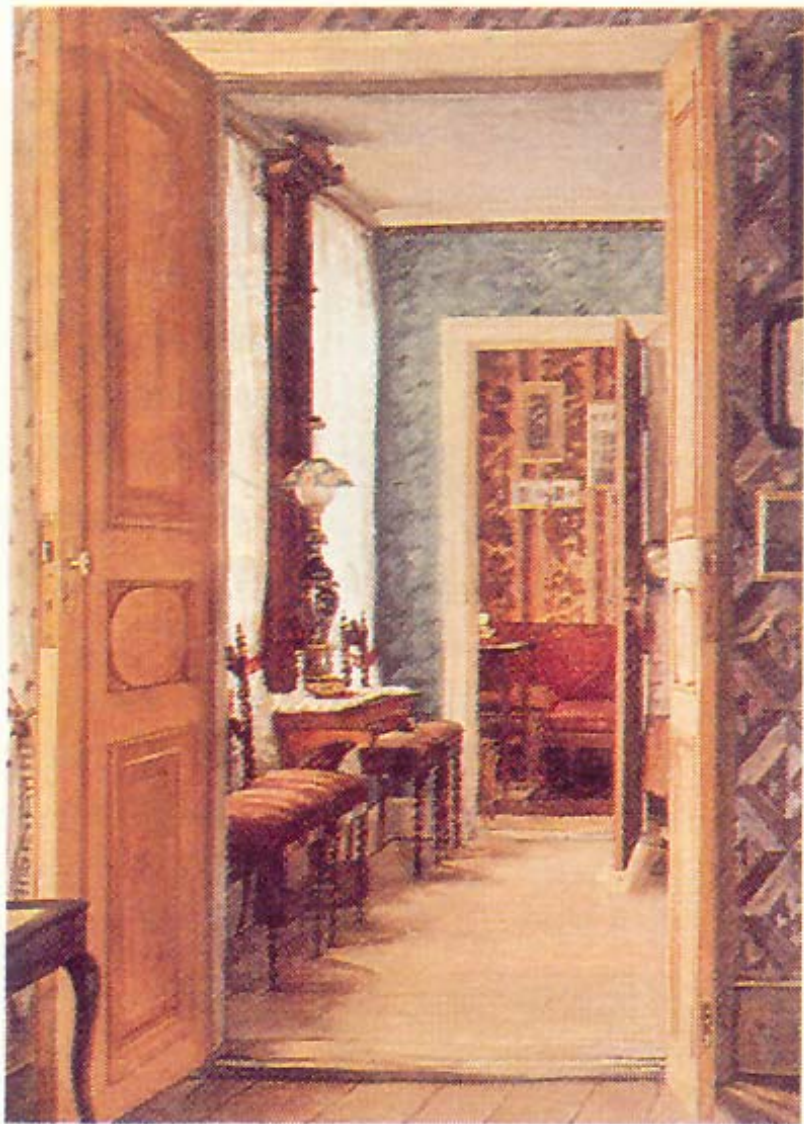

*W Lagerholm: Interiör från
Norra Smedjebacken 4, Örebro, 1871*



*H Matisse: Interiör
med grammofon 1910*

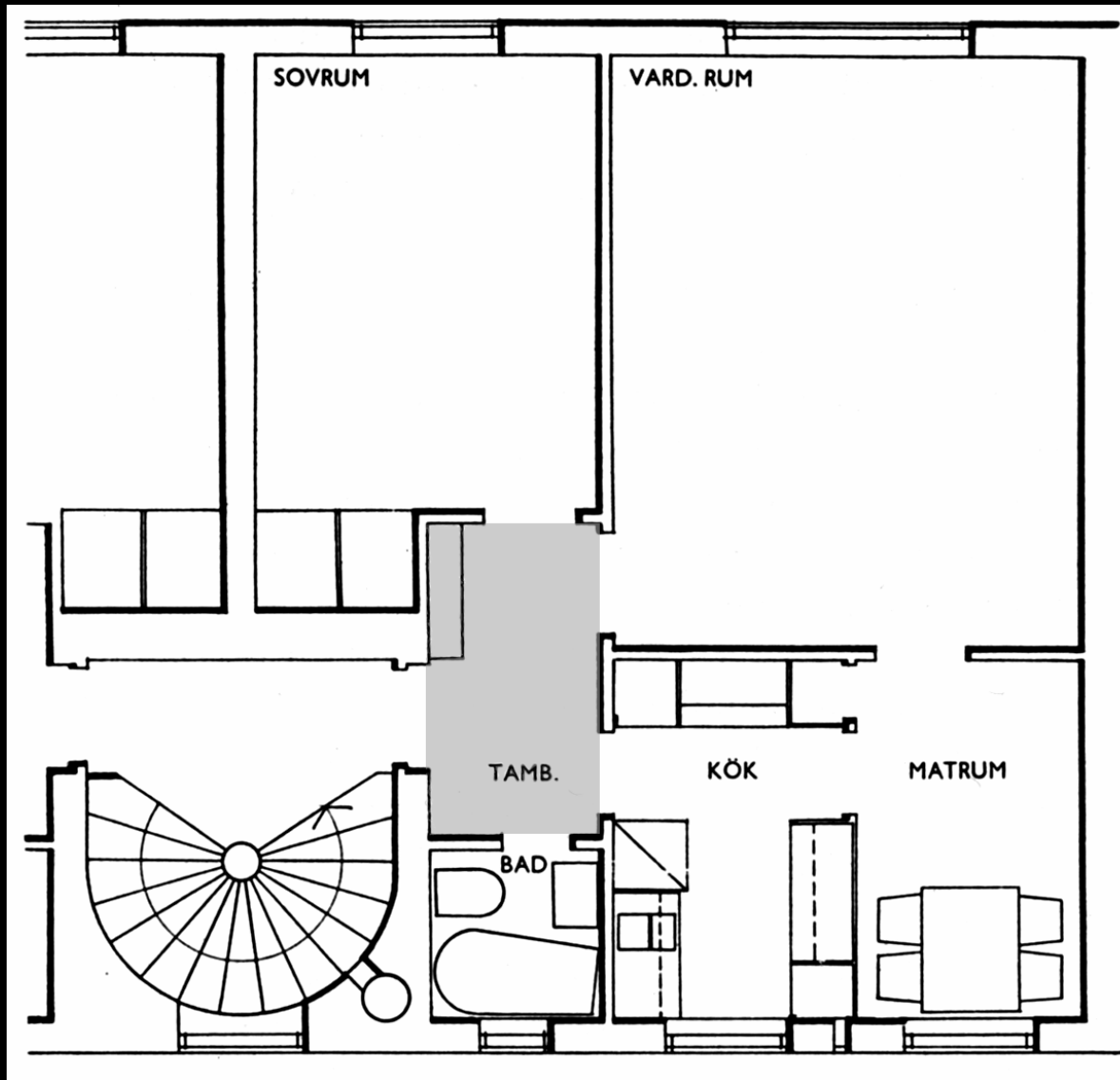

The neutral hallroom

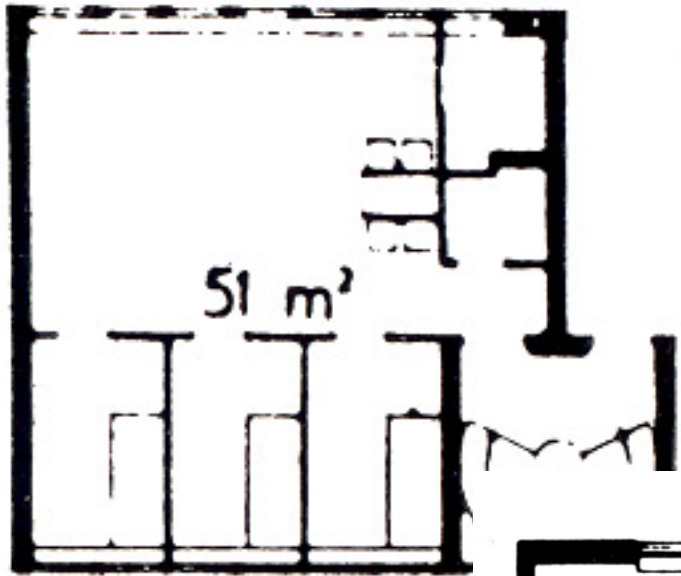

1950



1930

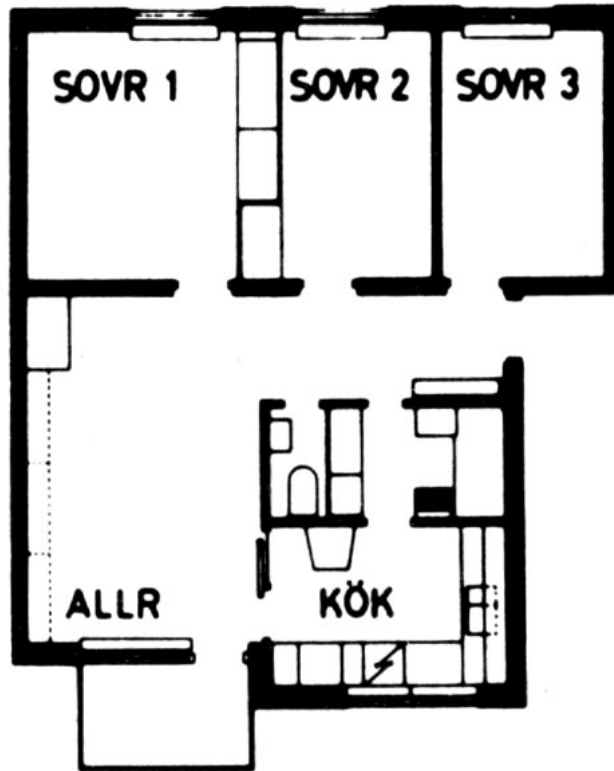

2000



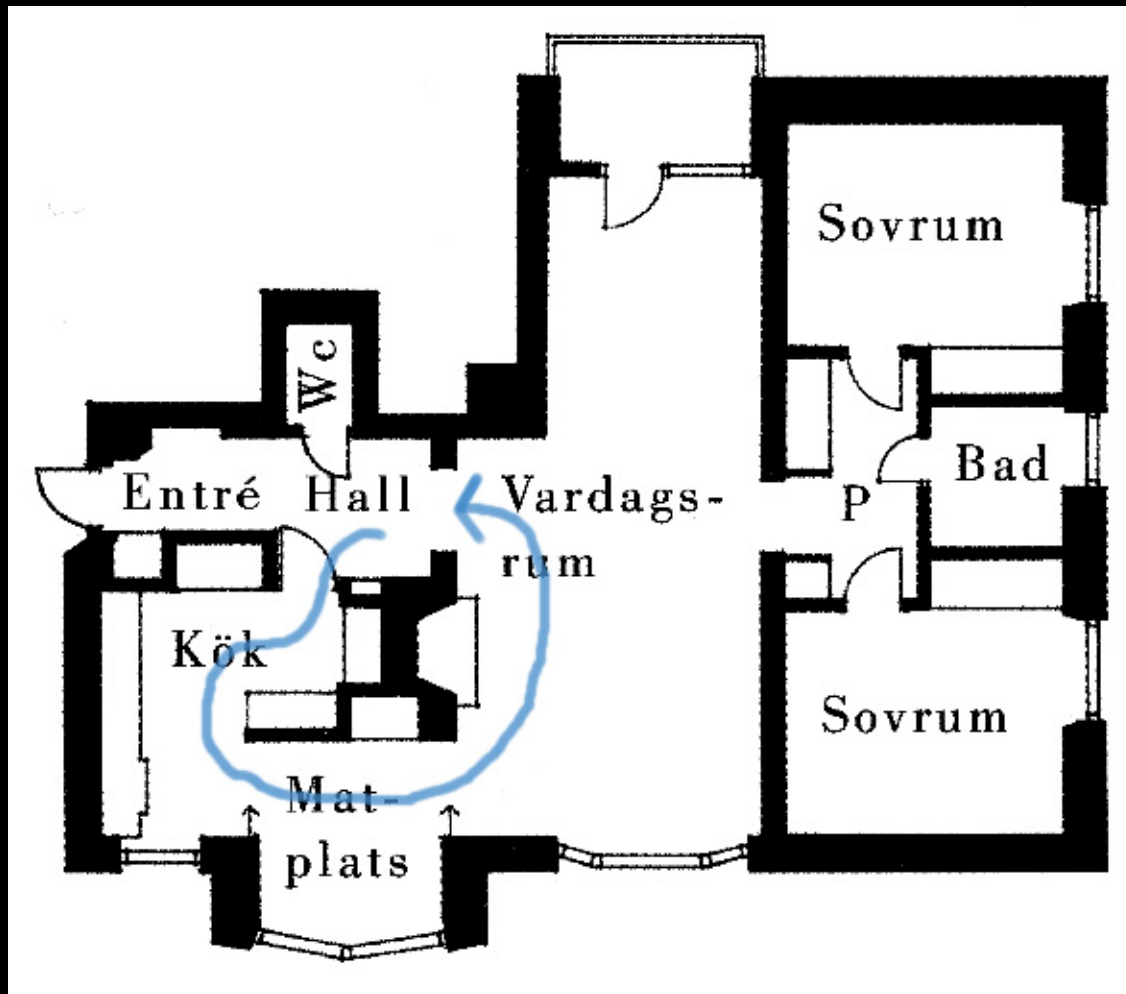

Circular loop











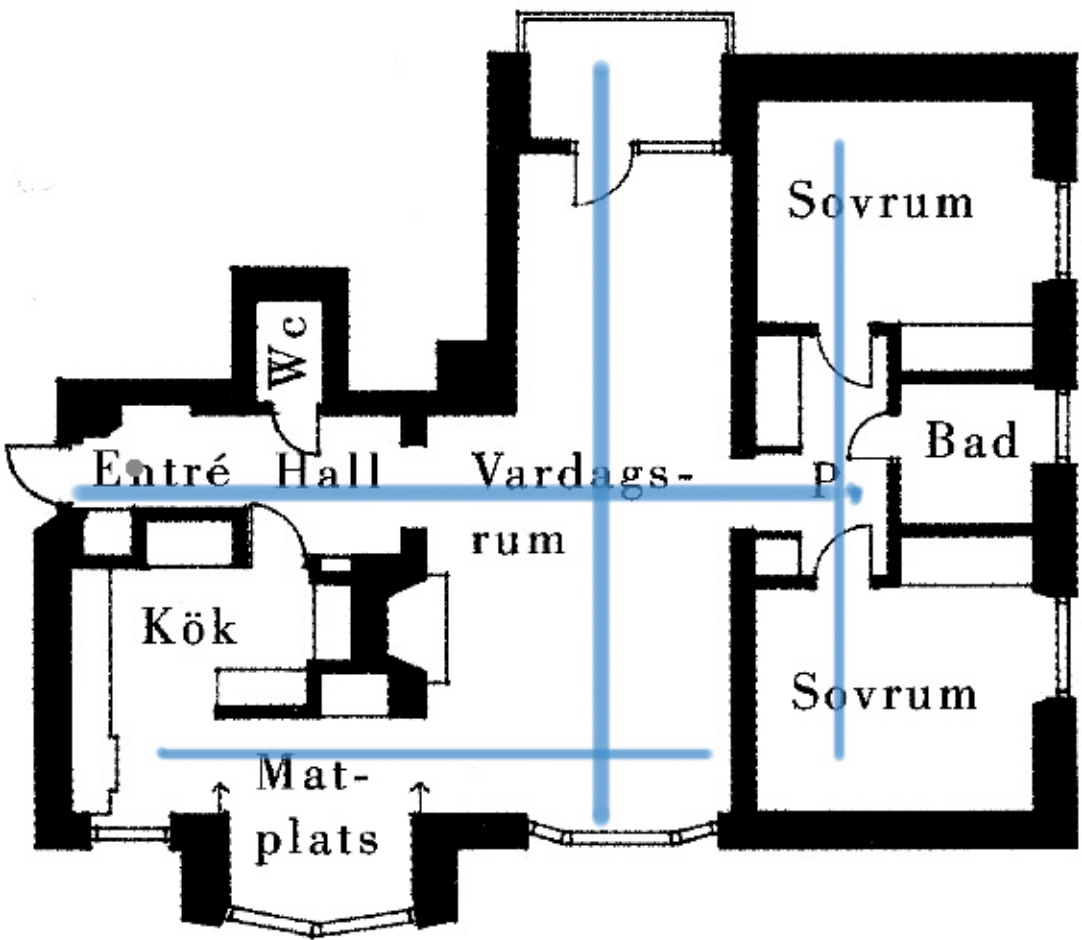

Movement as a function

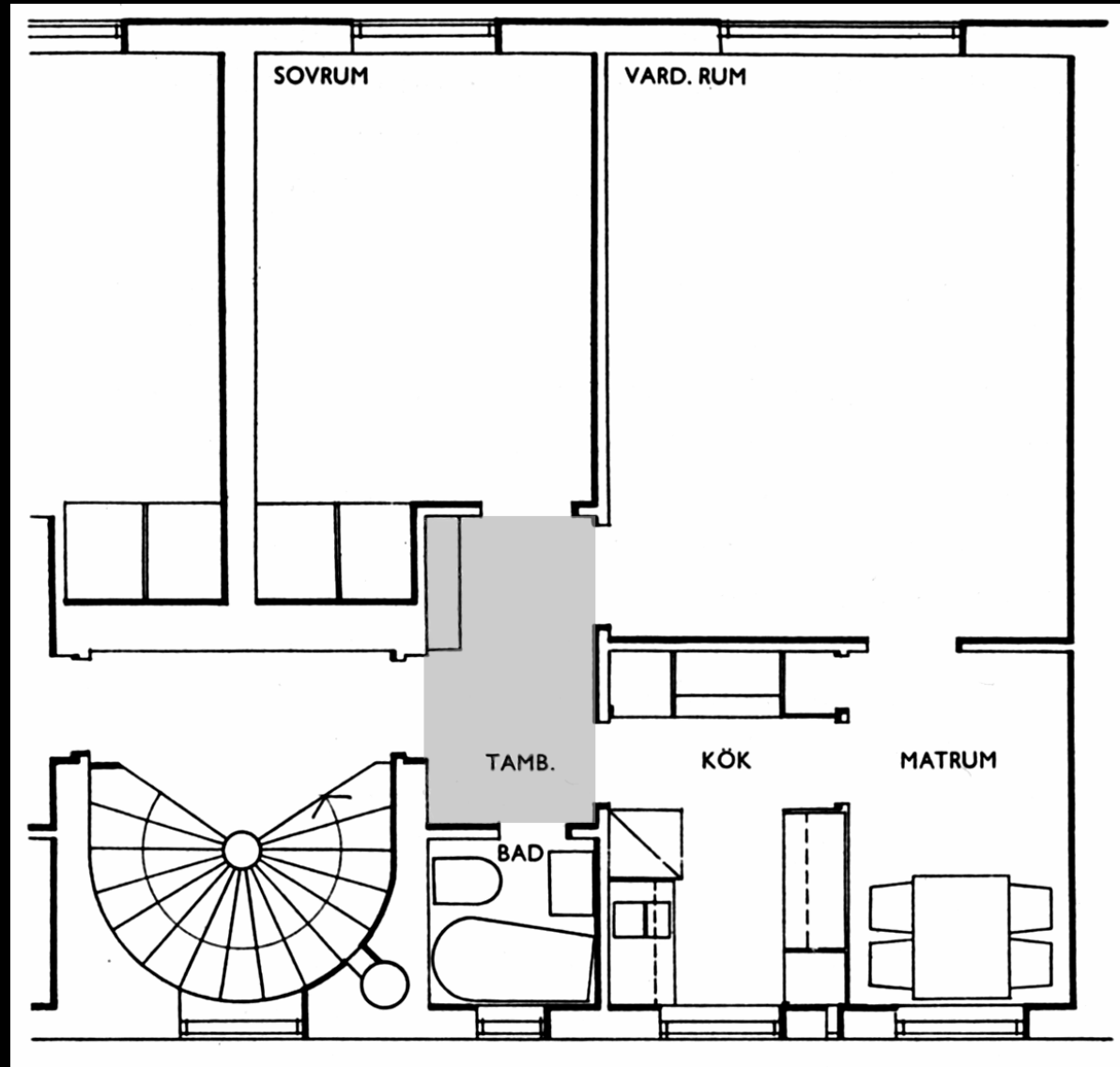

The New Home

Movement as architecture



Delsjövägsparken

Örgryte



Skanska Nya Hem
utvecklar ett bekvämt
boende i ett unikt läge

SKANSKA



Ulla Antonsson, White architects
Volymes, facades

Ola Nylander – Floor plans

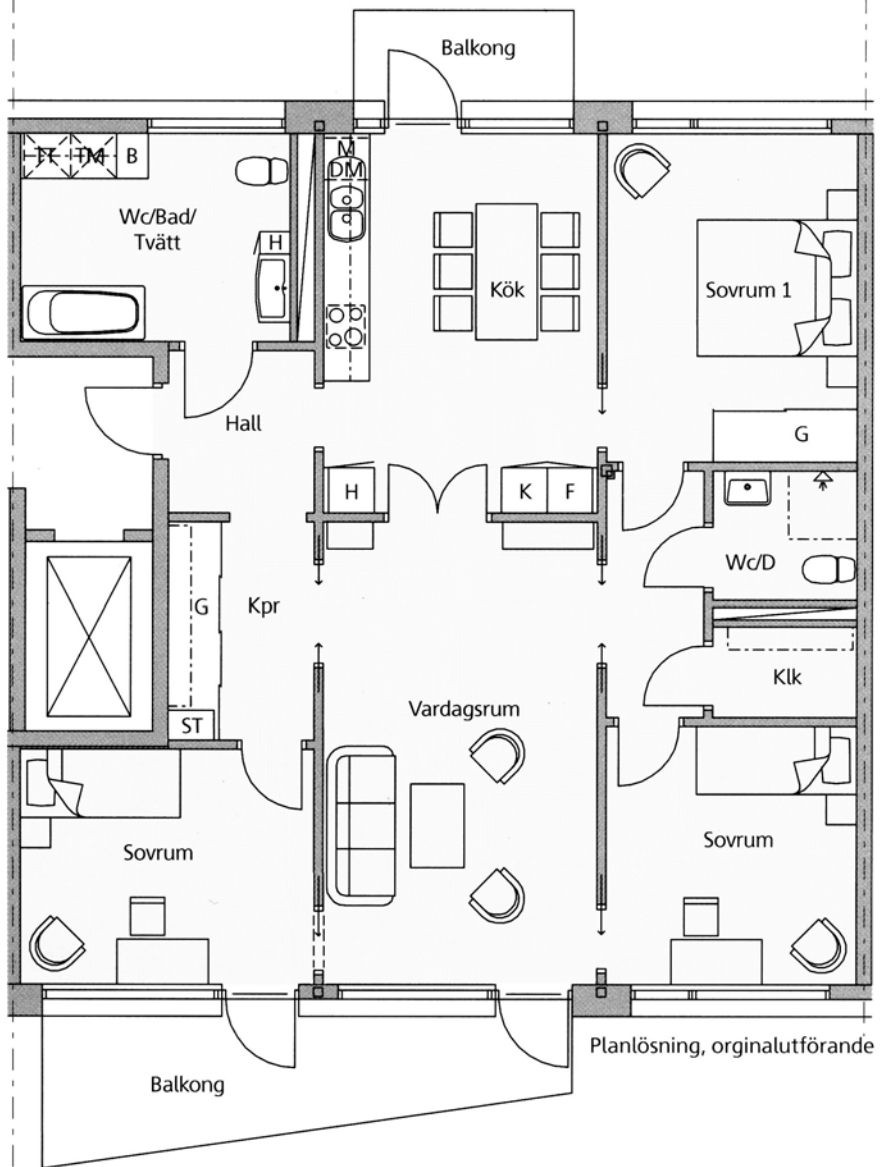

4 room + kitchen | 10 kvm

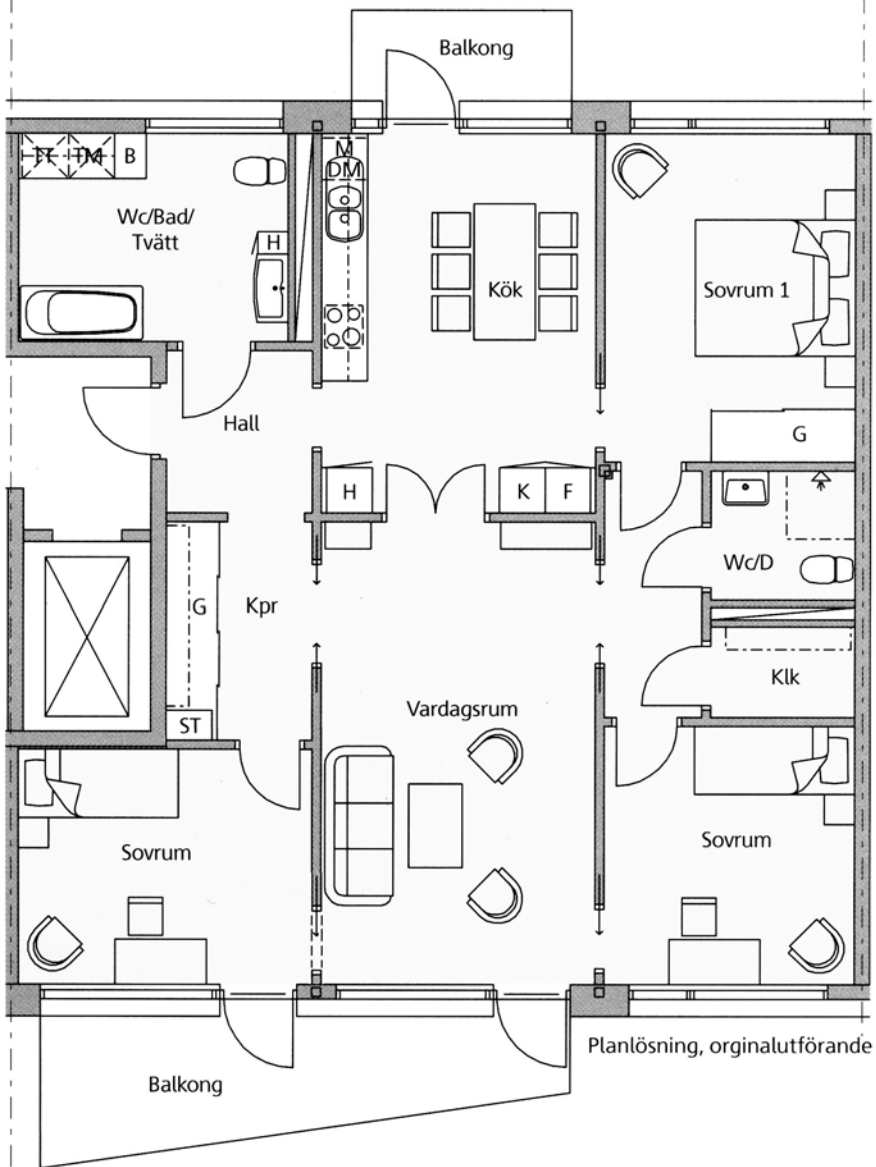

Light from two directions

Large terraces

**Cooperation between
inside - outside**

4 room + kitchen | 110 kvm

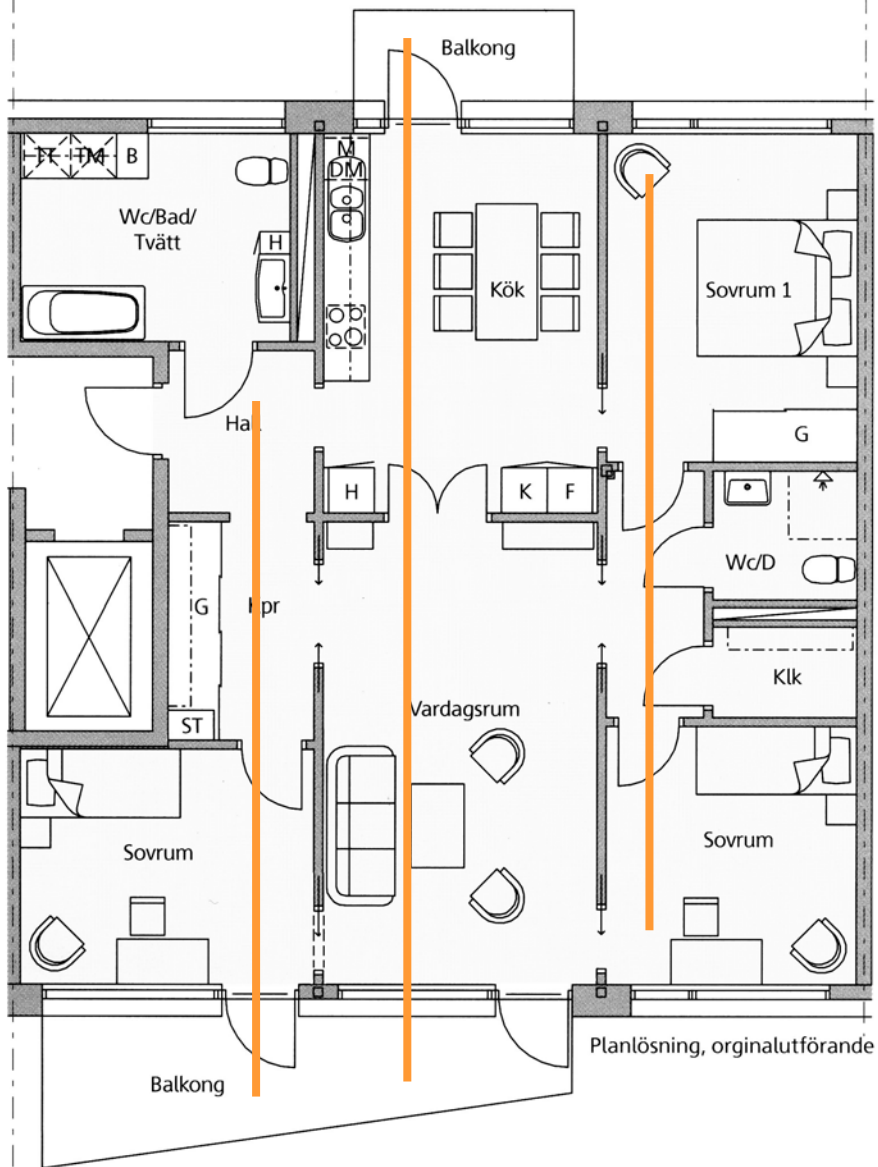

Light from two directions

Large terraces

**Cooperation between
inside – outside**

**Axiality - Atmosphere, and
rich experience**

4 room + kitchen | 10 kvm

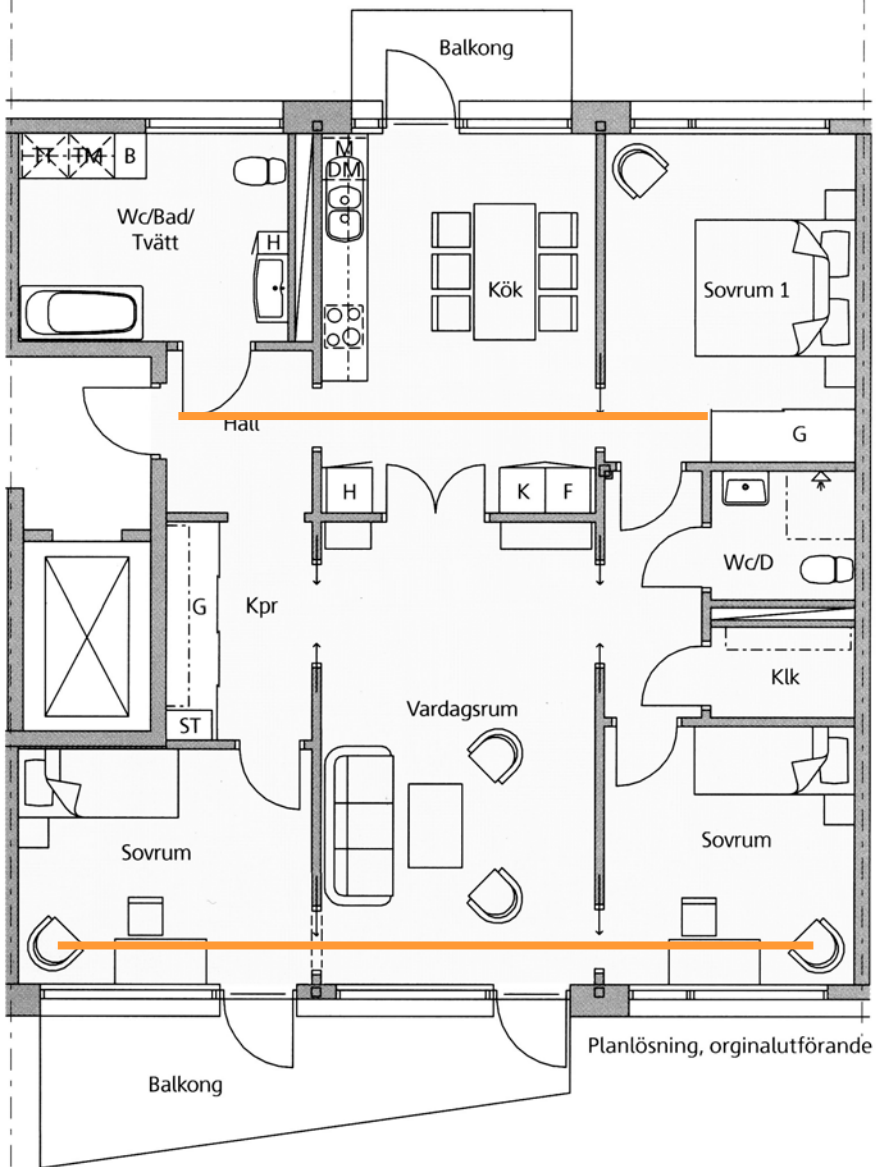

Axiality - Atmosphere, and rich experience

Different kinds of light and movements

4 room + kitchen | 10 kvm

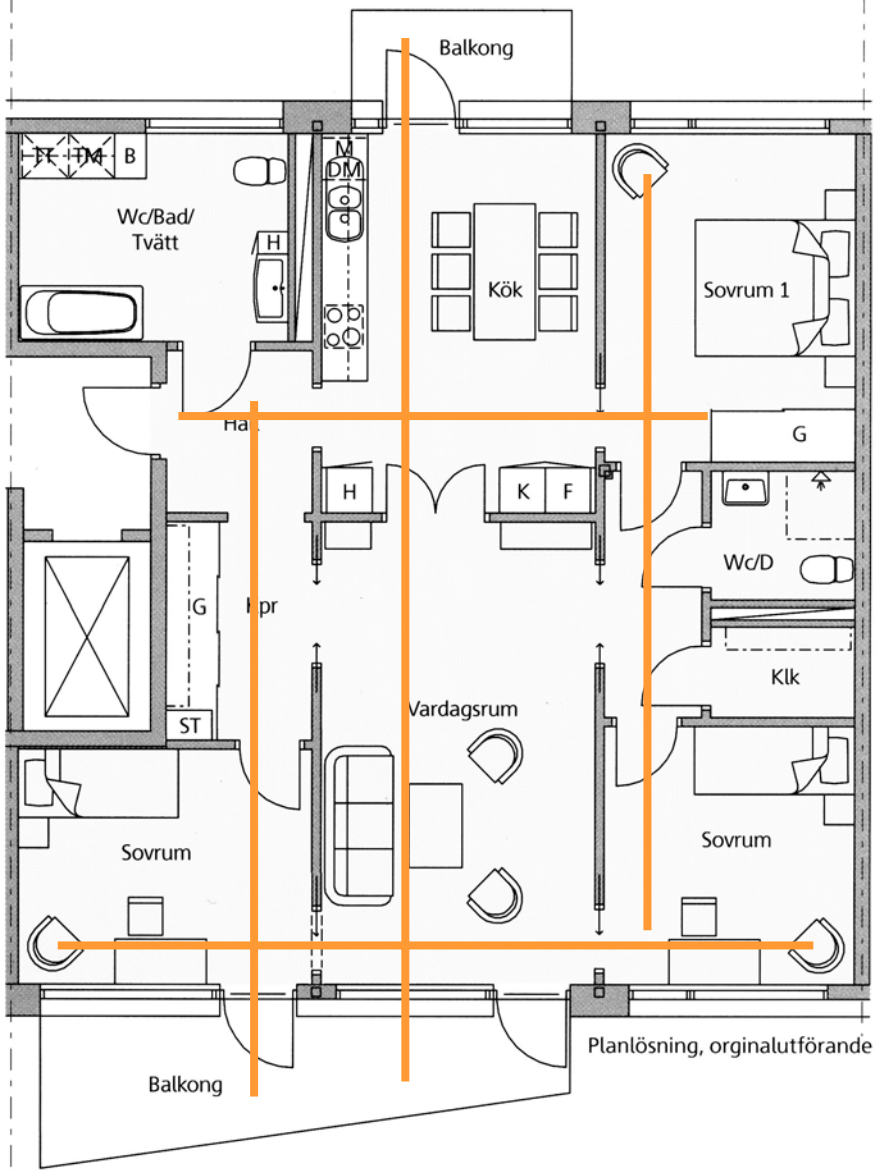

The rooms are interconnected with paths and sightlines.

4 room + kitchen | 10 kvm

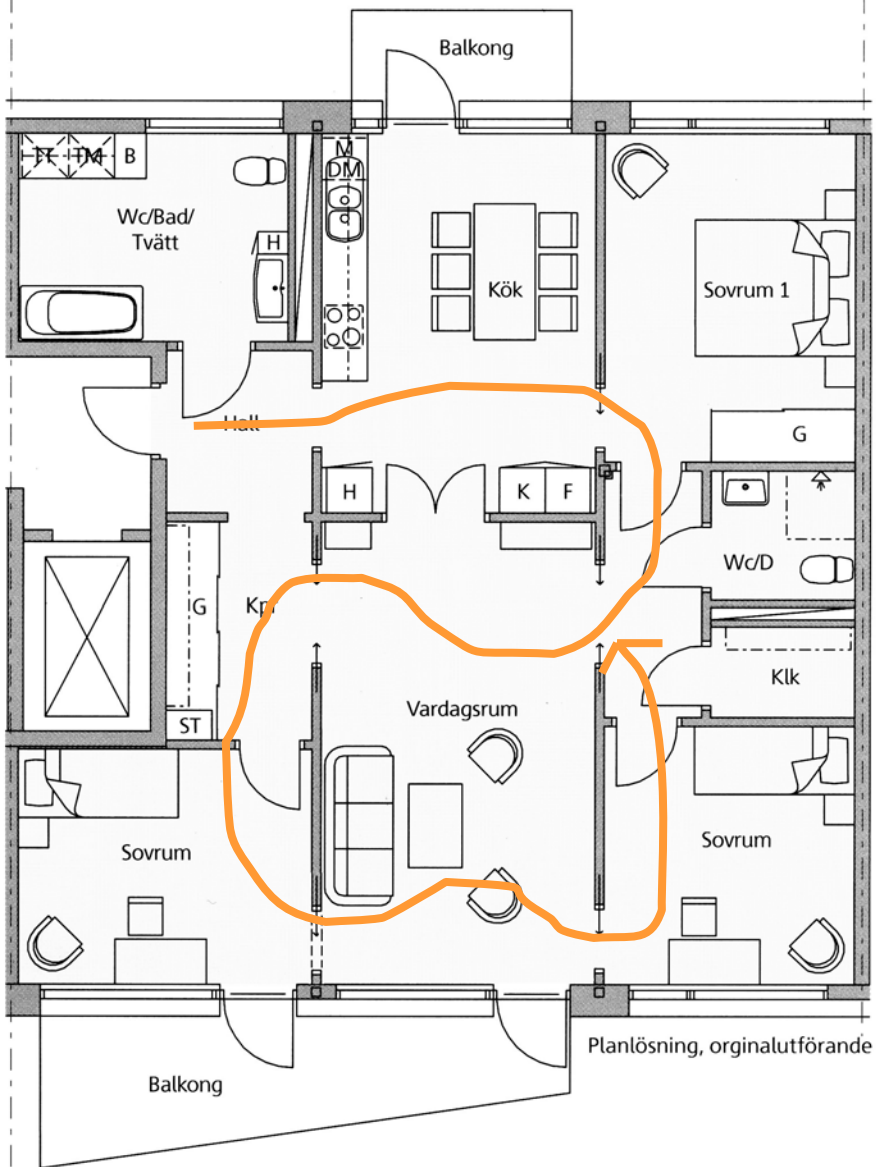

Movements
Movements through a chain of rooms.
Inside - outside
Circular loop
Possibilities to chose different ways and paths in the apartment

4 room + kitchen | 110 kvm

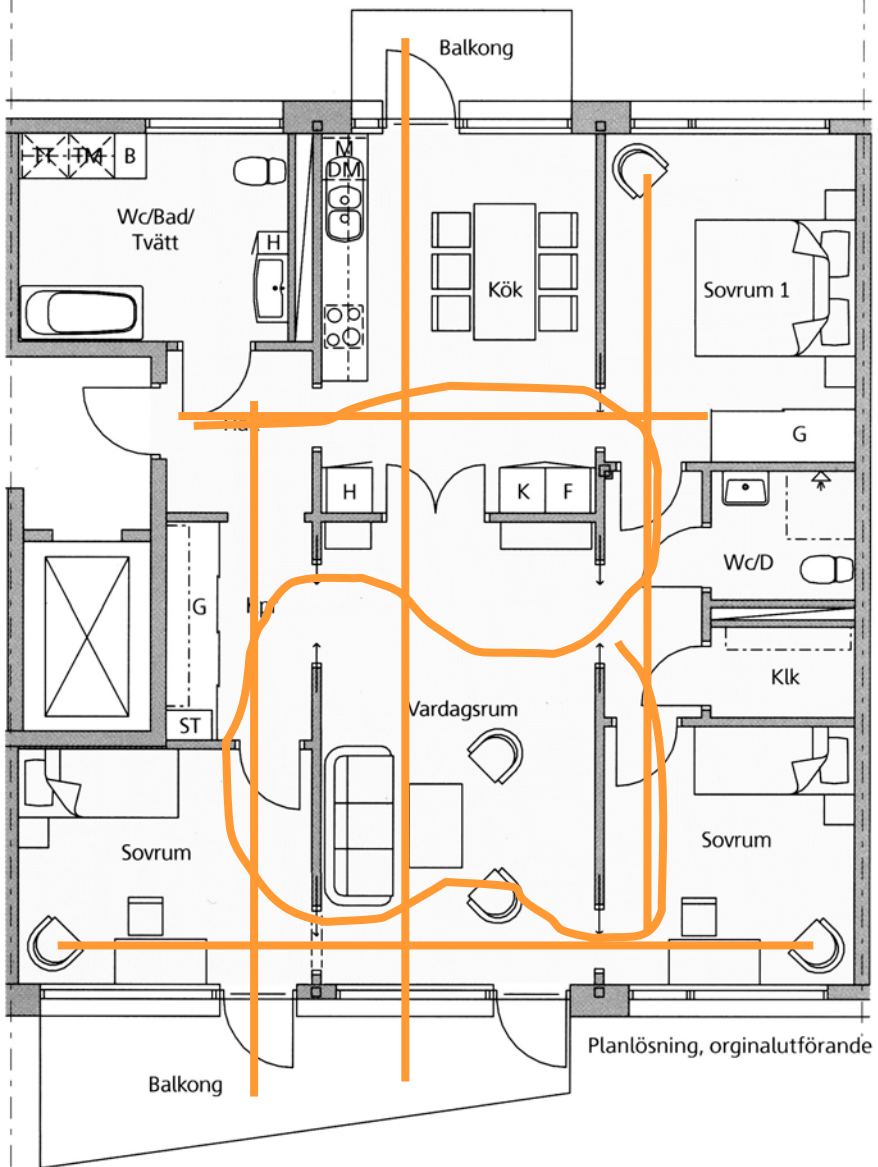

4 room + kitchen | 110 kvm

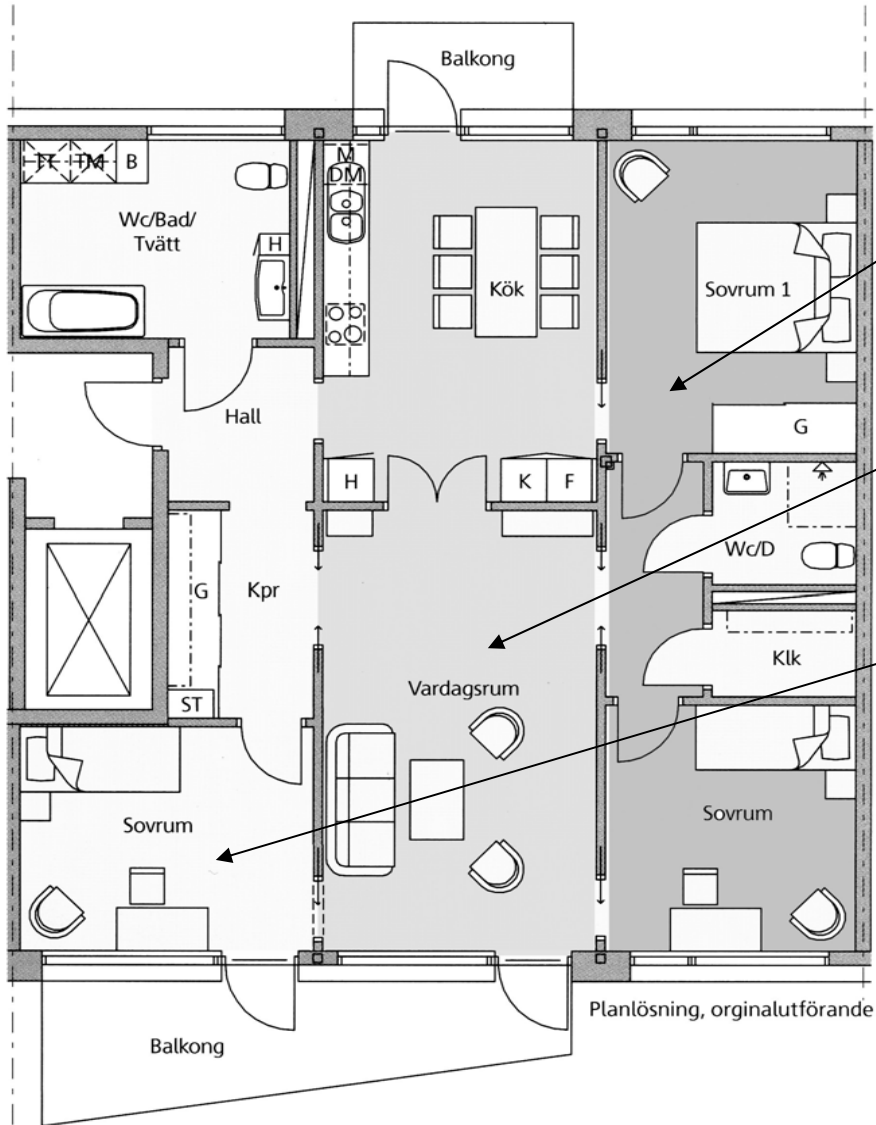

Private

Public

**Possible workplace –
public part of the
Home**

**General rooms with
3,3x3,9m and two
(ore moore) doors in to
ewery room**

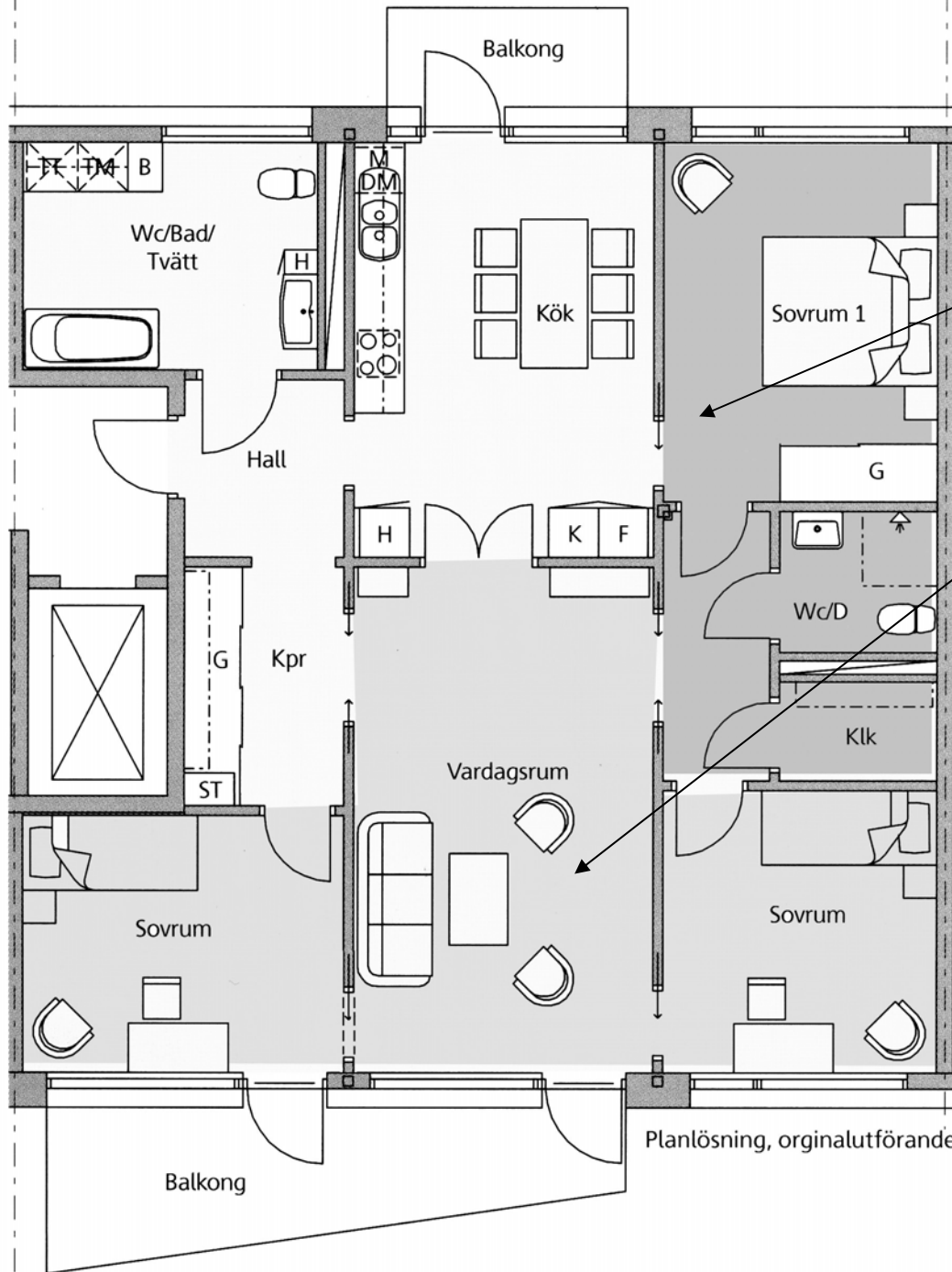

Private

Public

**Allow for flexibility
of use.**

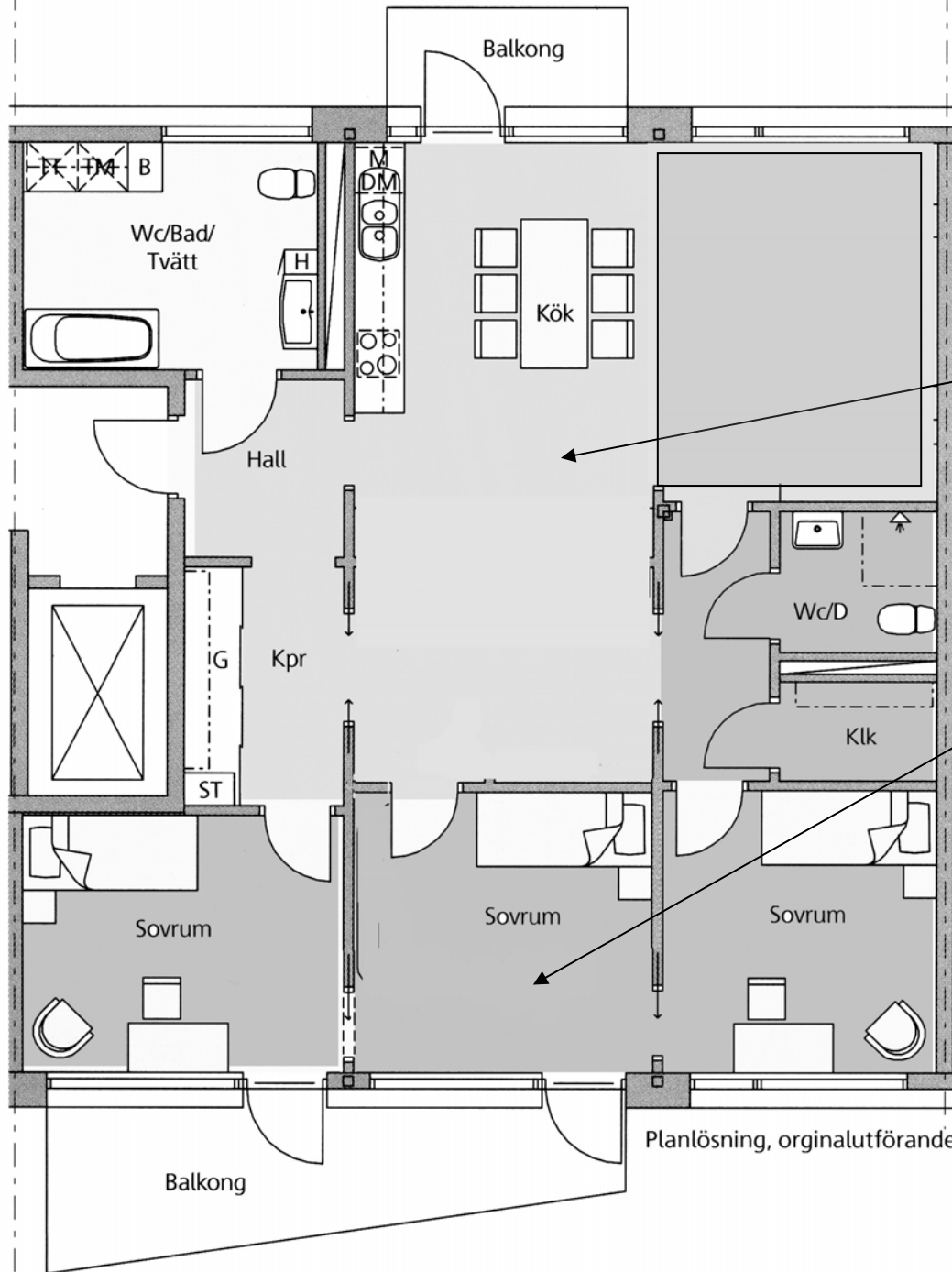

Public

Private

The residence decides themselves – respect and trust

Depth of interpretation

The new, inspiring apartment

The situation

The room

The organisation of space

The future

The new, inspiring apartment

The situation

The room

The organisation of space

The future

Low Energy Houses

Industrialisation

Pumpkällehagen



Low energy houses

Pumpkällehagen 4

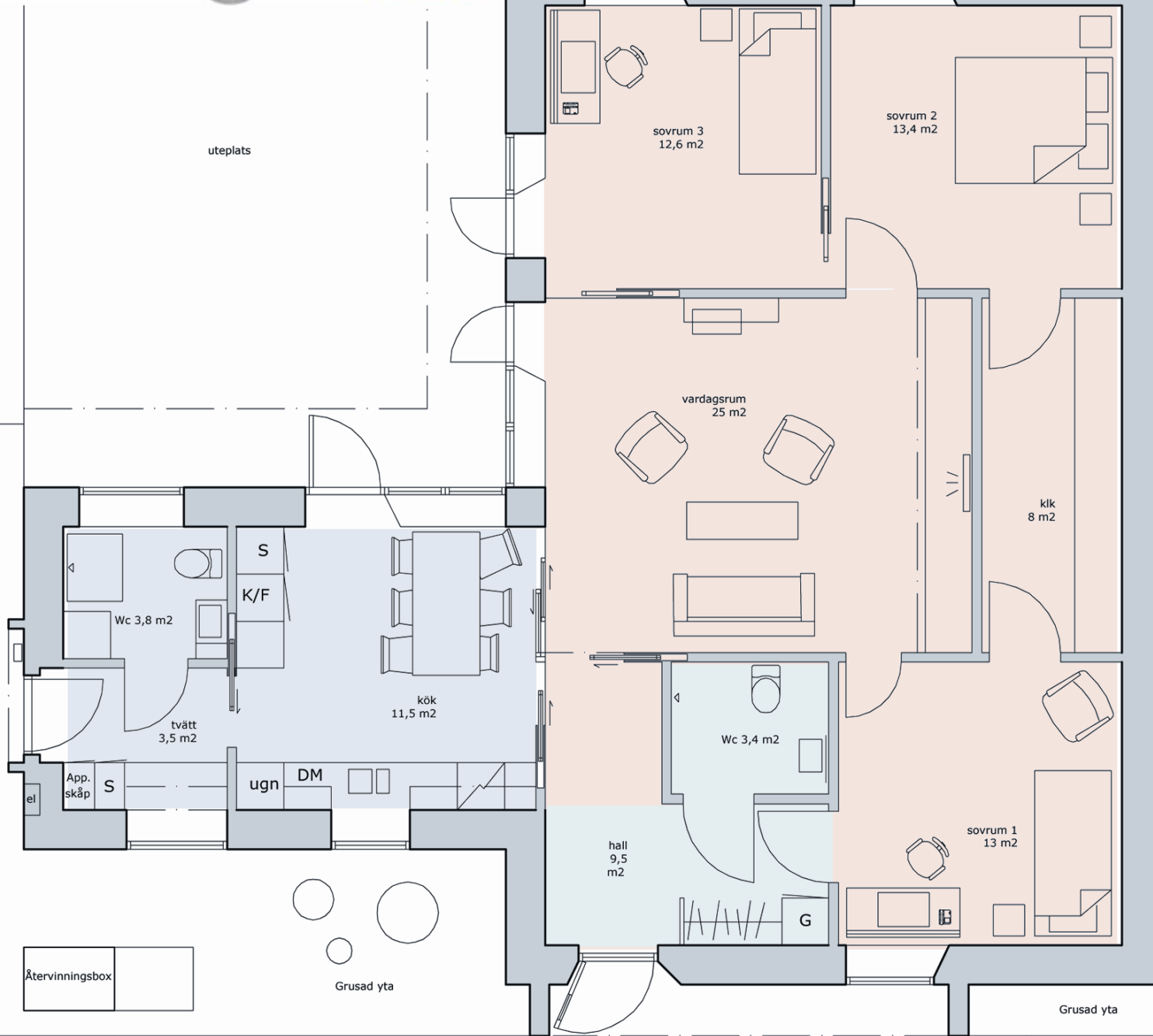

Industrialisation

Possibilities – architectonic
qualities



The new, inspiring apartment

The situation

The room

The organisation of space

The future

Customers market



The Answer on Customers market?

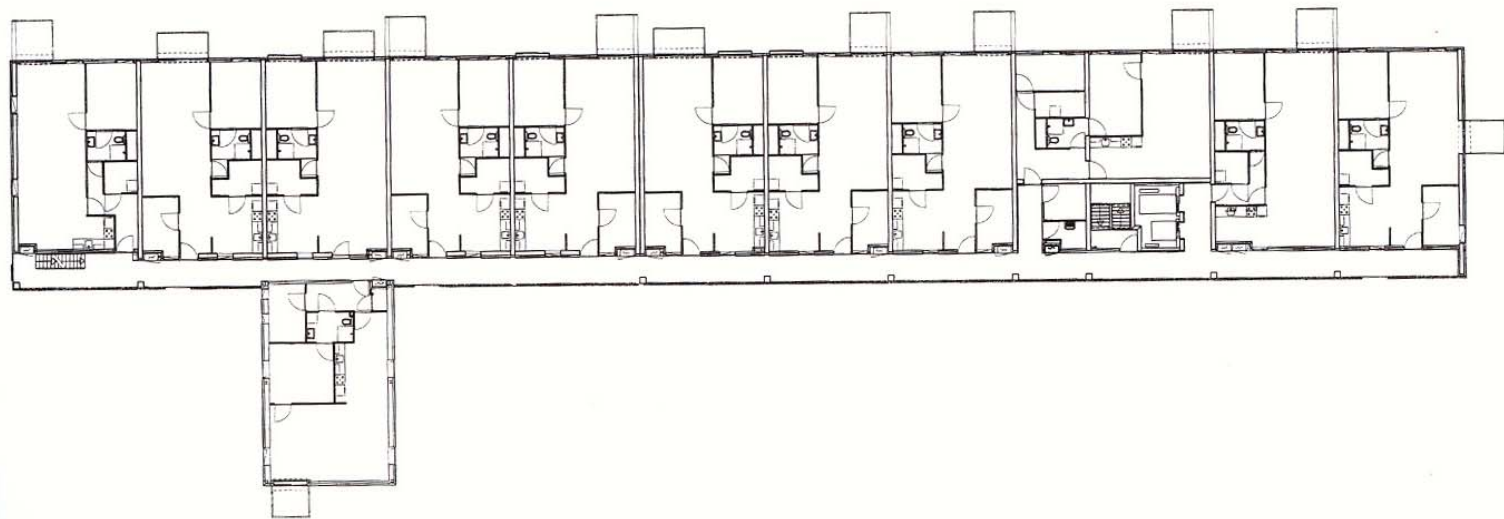

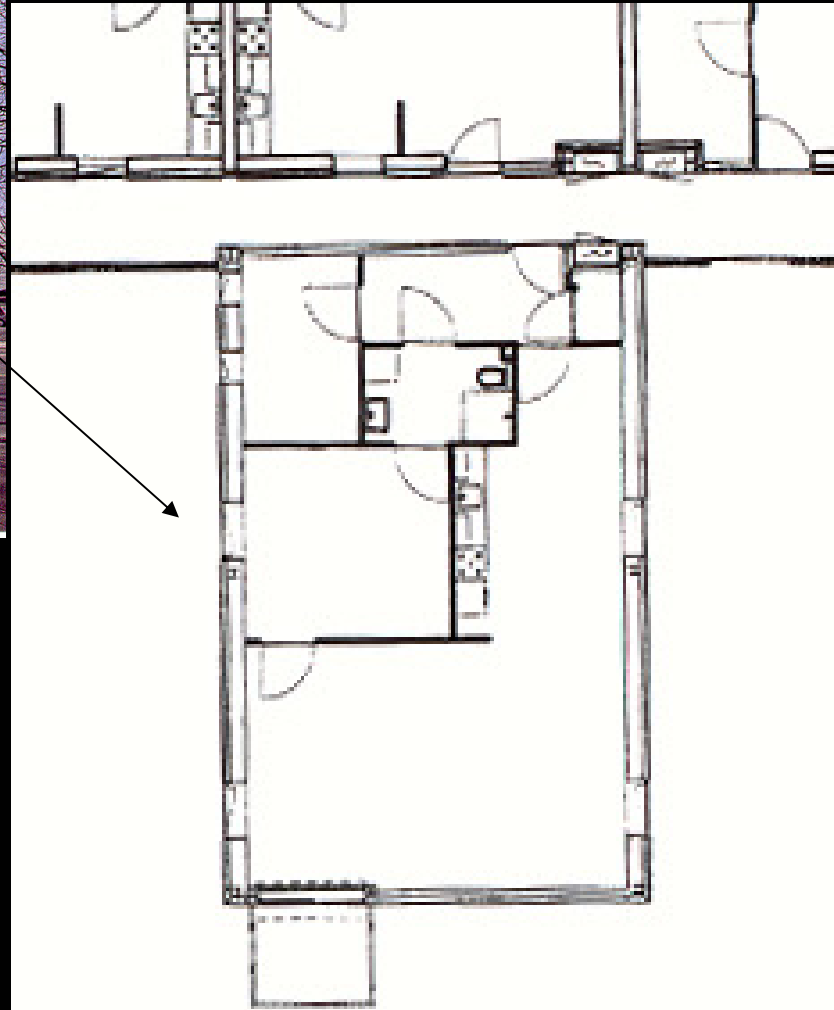

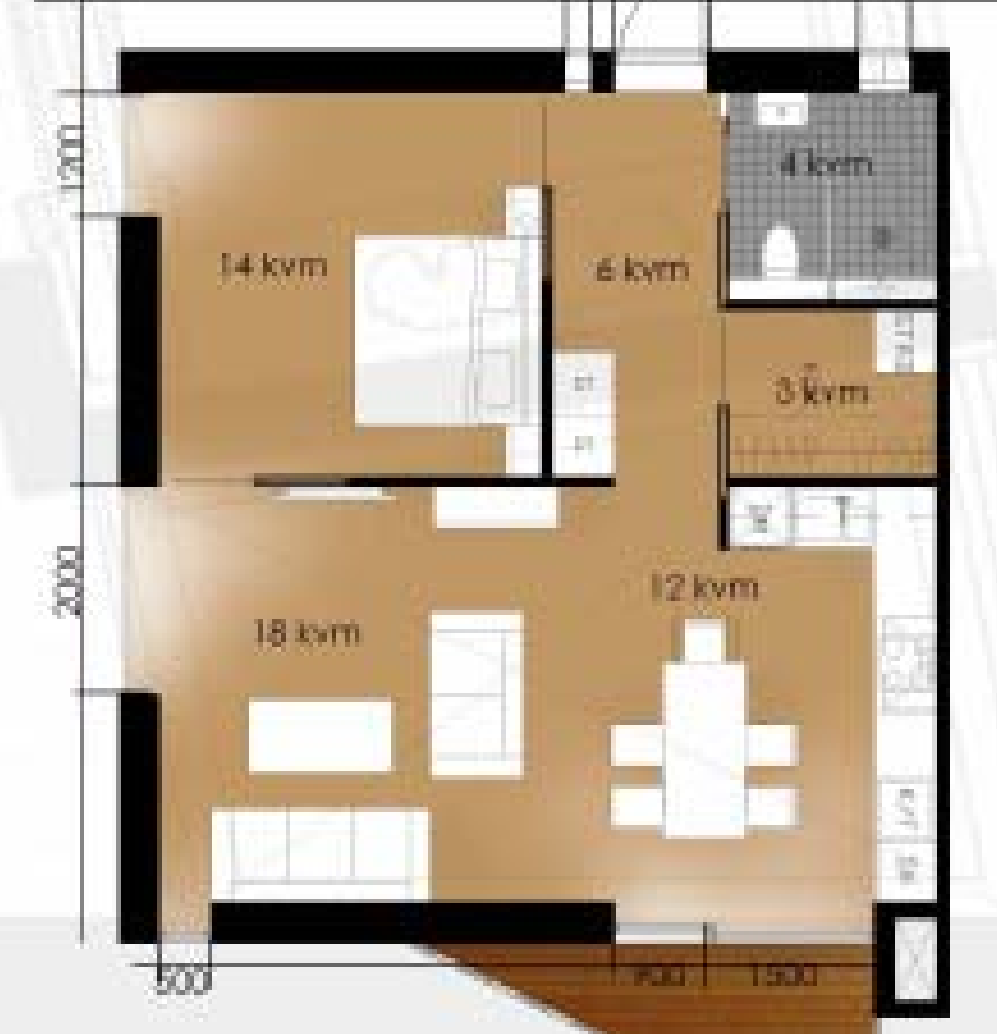

Studentproject 2007

2 room and kitchen
57kvm

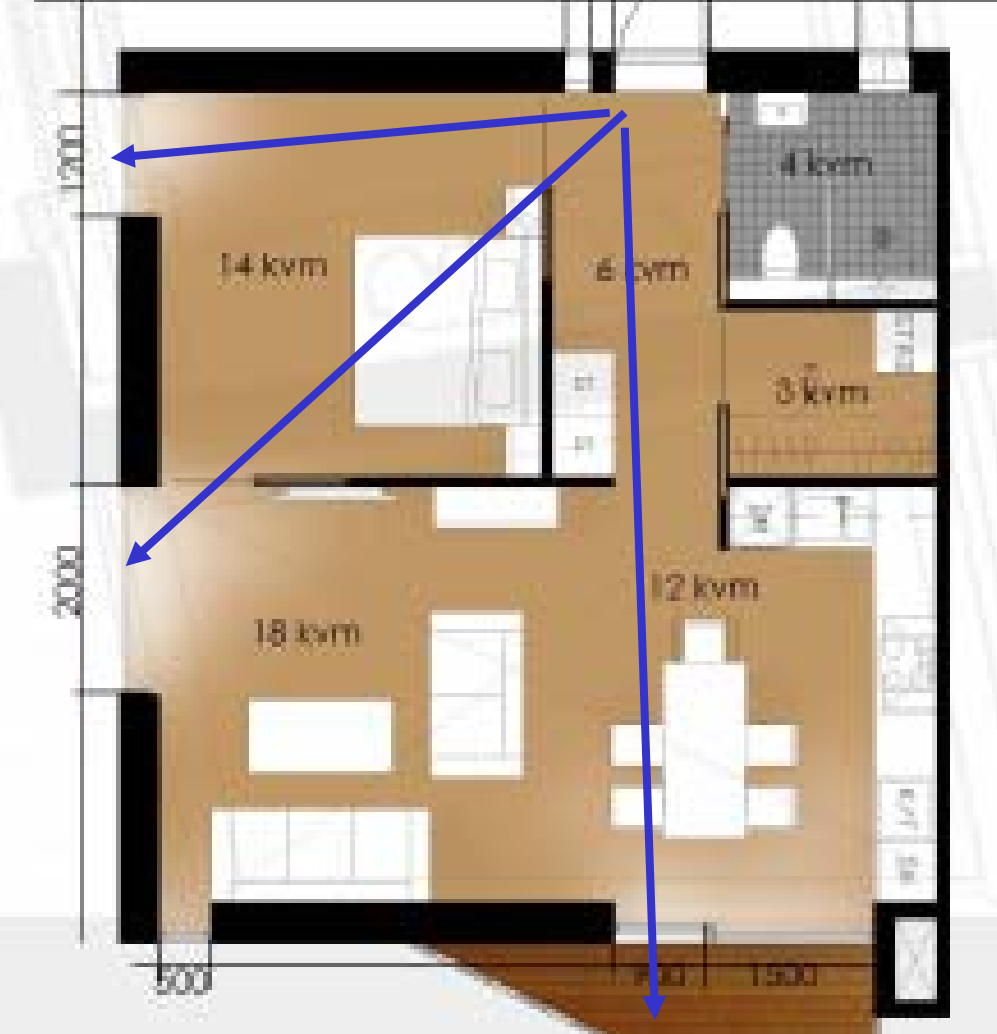

Sightlines
Axiality
Circular loop

Studentproject 2007

2 room and kitchen
57kvm



Customers market

Freedom of choices

Freedom – order



Studentproject 2007

2 room and kitchen

57kvm



Studentproject 2007

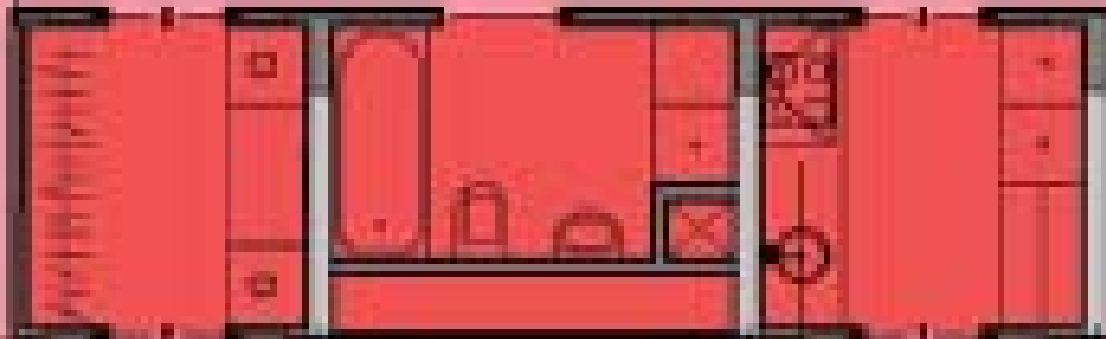

Studentproject 2007

Possibel flexibel

1.003 2.852 2.852 3.043 3.002 2.038 1.132



Plan vping 1 3 5 1:100

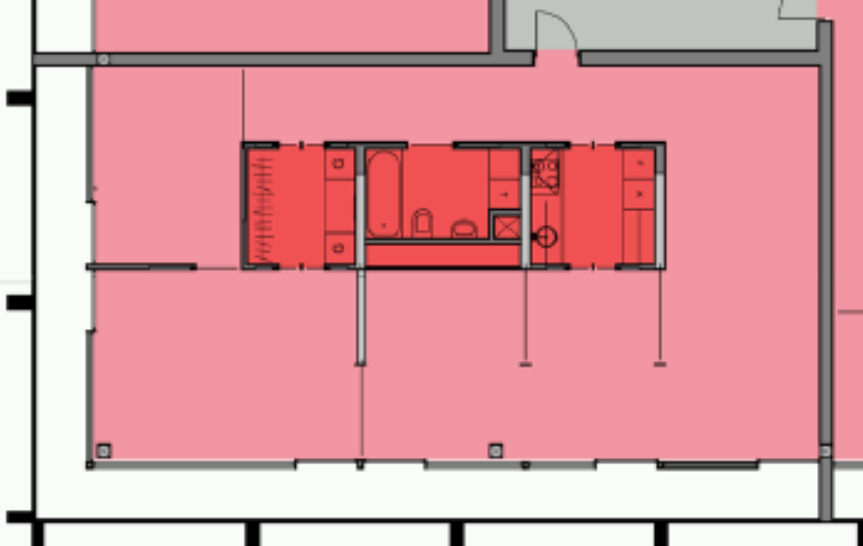

R Florida: The Rise of the Creative Class

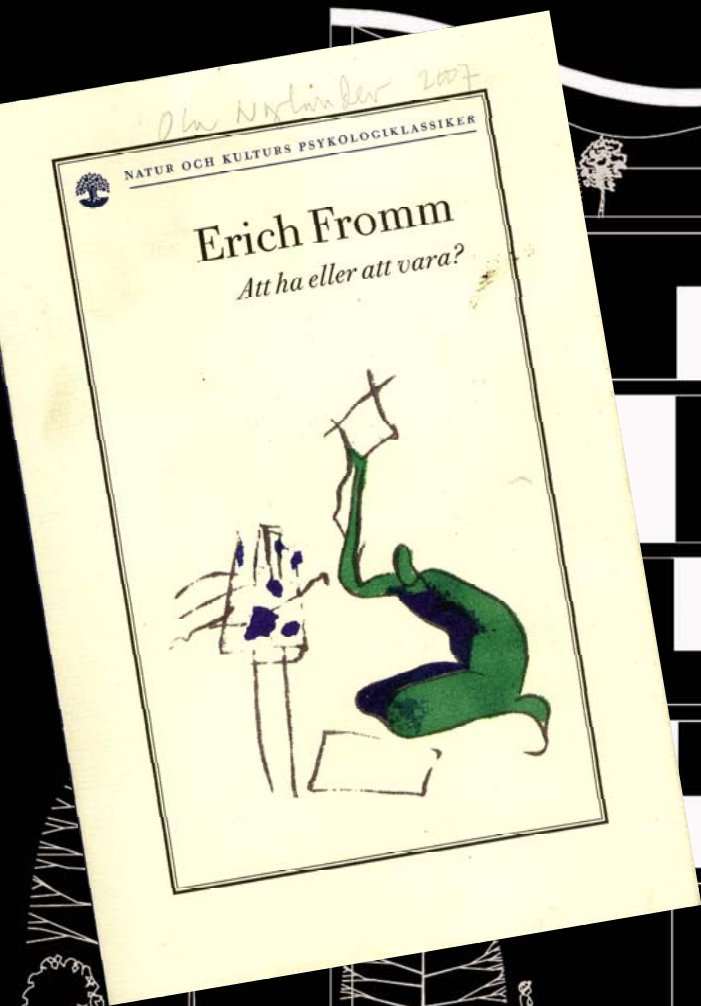

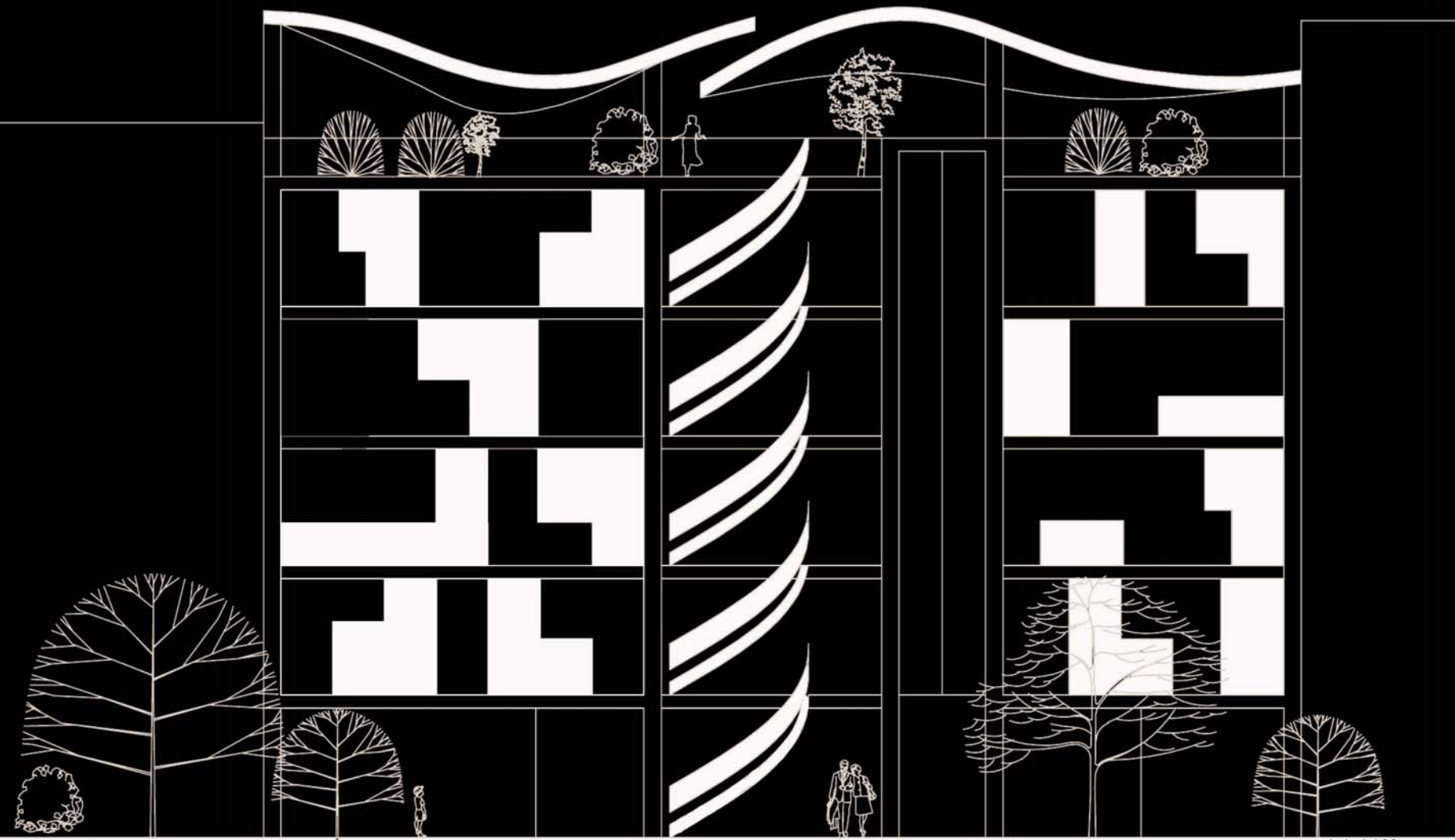

Sustainability - materialism

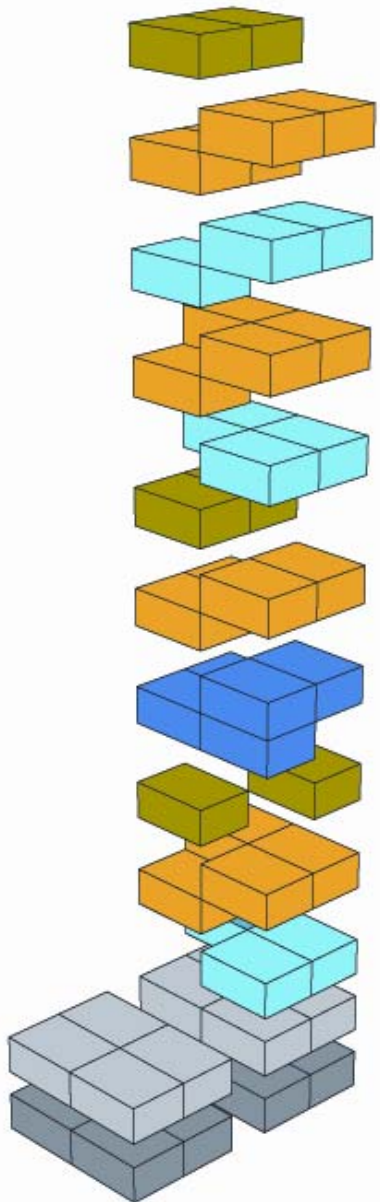

Planer 1:200

Axiality

Movements

Expansion



Flexibility

Private - public

Inside - outside

**My
place**



**My
place
Individuality**



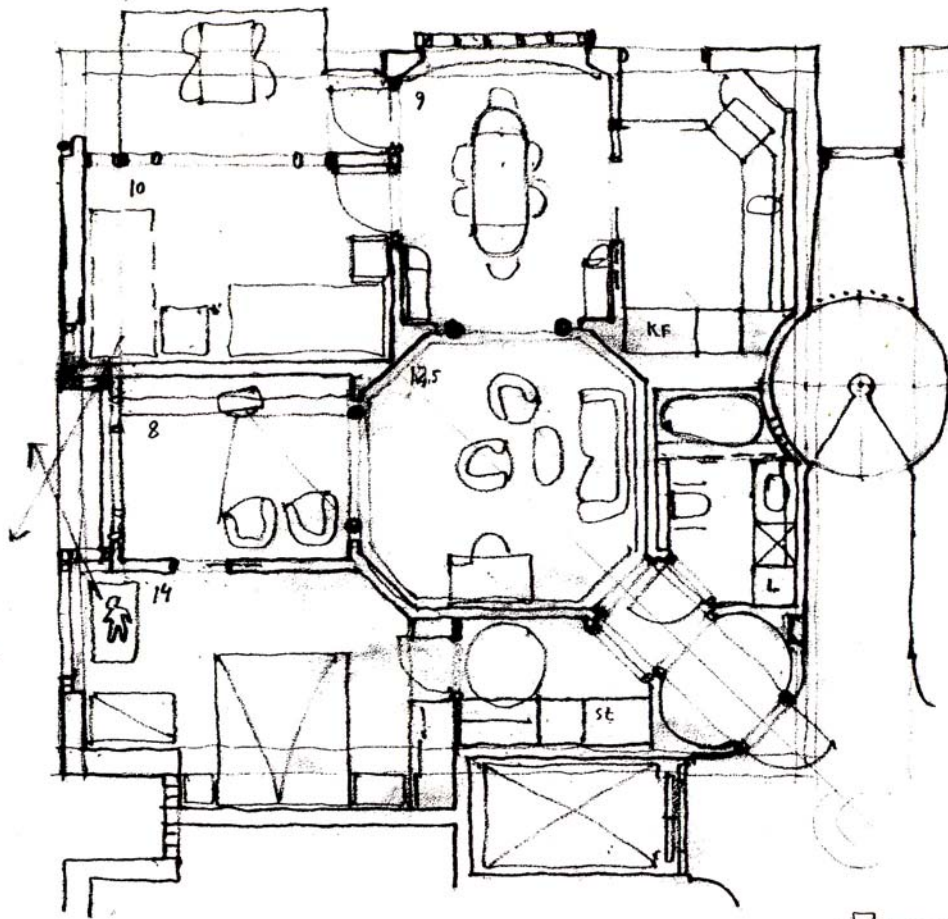

**The new, inspiring
apartment**

The situation

The room

**The organisation of
space**

The future

**Customers
market**

Architecture